



ELEVATOR PARTS



**GALAXY FUJI ELEVATOR CO., LTD**

Galaxy Fuji lift you up

**GALAXY FUJI ELEVATOR CO., LTD**

Address: 1st Floor, No. 10, Lane 255, Xiaotang Road, Fengxian District, Shanghai, China

KATHERINE

MP: +86 19888125655

Email: [katherine.galaxyfuji@gmail.com](mailto:katherine.galaxyfuji@gmail.com)

CHARLEY

MP: +86 13671543901

Email: [charley.galaxyfuji@gmail.com](mailto:charley.galaxyfuji@gmail.com)

Facebook: Galaxy Fuji Elevator





# CONTENTS

---

<b>Company Profile</b> .....	01
<b>Door System</b> .....	03
<b>Electric System</b> .....	13
<b>Traction System</b> .....	27
<b>Guide Rail and Balance System</b> .....	35
<b>Safety Components</b> .....	39
<b>Cabin System</b> .....	43
<b>Anti-epidemic Products</b> .....	53
<b>Escalator Parts</b> .....	57



We have been growing to become the market and innovation leader for elevator business. Our company, which has been acting with the experience and knowledge gained in the sector for many years, continues to maintain its friendly and quality service understanding.

Our company is based on marketing experience. It is our challenge to enable clients to turn opportunities into real value-added business. We offer machines and services with high value retention. By doing so, we ensure process reliability and efficiency for customers all over the world. We perform fully detailed market analysis and define jointly with you the required measurements and actions.

With the knowledge and experience that years have contributed to us, we ensure that our products meet with the end consumer by determining the correct market analysis and hot sales channels on site. That's what define us and what motivates us.



# Door System

- Mitsubishi Door Operator
- Selcom Door Operator
- Fermator Door Operator
- Door Operator Parts
- Elevator Light Curtain
- Synchronous Belt & Synchronous Pulley
- Fireproof Door Operator Accessories

## ▶ Mitsubishi Door Operator



·GF-MVY-211  
Center Opening Two Panel Operator  
(Car Frame Installation)



·GF-MP-211  
Center Opening Two Panel Operator  
(Car Frame Installation)



·GF-MP-211  
Center Opening Two Panel Operator  
(Car Frame Installation)



·GF-MVT-211  
Center Opening Two Panel Operator  
(Car Frame Installation)



·GF-MVT-211  
Side Opening Two Panel Operator  
(Car Frame Installation)



·GF-MVT-211  
Side Opening Two Panel Operator  
(Car Frame Installation)



·GF-MVT-411  
Center Opening Two Panel Operator  
(Car Frame Installation)



·GF-LM-211  
Center Opening Two Panel Operator  
(Car Frame Installation)



·GF-LS-211  
Center Opening Two Panel Operator  
(Car Frame Installation)



·GF-LM-201  
Center Opening Two Panel Operator  
(Car Frame Installation)



·GF-LM-411  
Center Opening Two Panel Operator  
(Car Frame Installation)

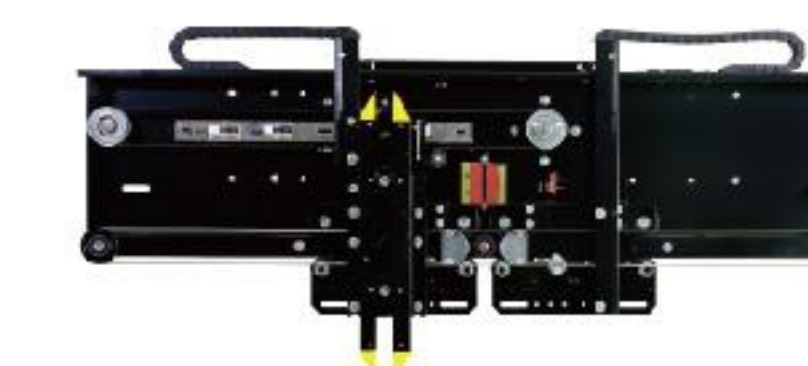

·GF-OV-211  
Center Opening Two Panel Operator  
(Car Frame Installation)



## ▶ Mitsubishi Door Operator



·GF-OZ-211  
Center Opening Two Panel Operator  
(Car Frame Installation)



·GF-OV-211  
Side Opening Two Panel Operator  
(Car Frame Installation)



·GF-OZ-210  
Side Opening Two Panel Operator  
(Car Frame Installation)



·GF-LO-211  
Center Opening Two Panel Operator  
(Car Frame Installation)



·GF-LO-210  
Side Opening Two Panel Operator  
(Car Frame Installation)

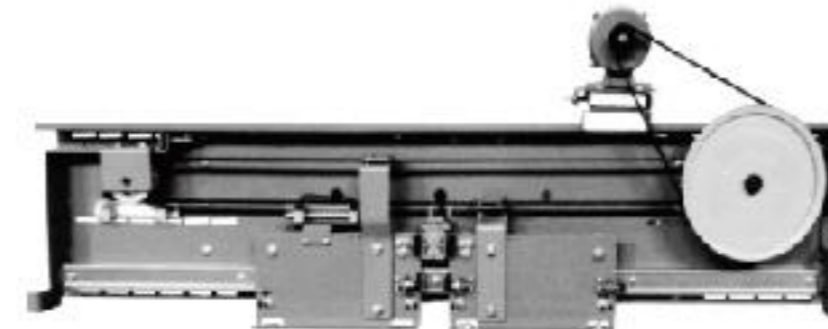

·GF-131-06A  
Center Opening VVVF Door Operator  
(Straight Beam Mounting)

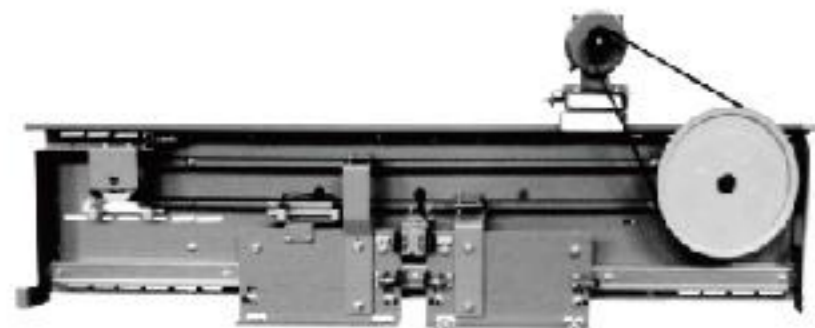

·GF-131-06B  
Center Opening VVVF Door Operator  
(Car Top Mounting)

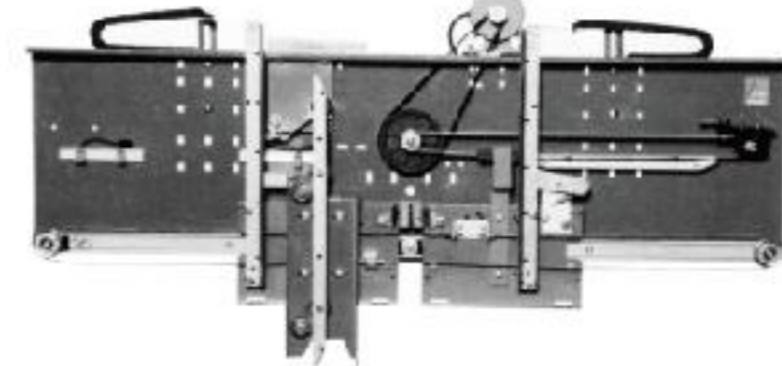

·GF-131-50-1A  
Center Opening VVVF Door Operator  
(Straight Beam Mounting)

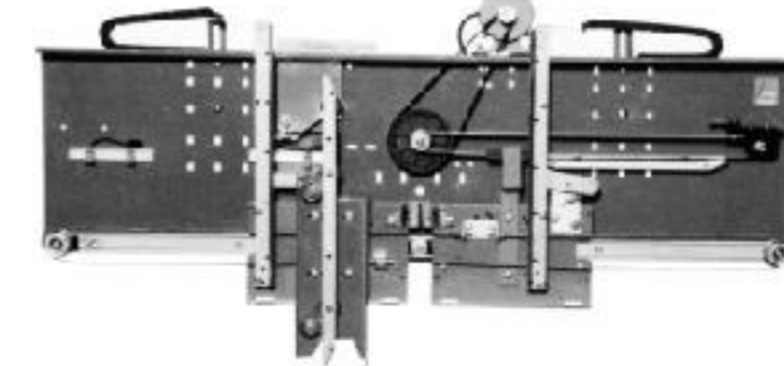

·GF-131-50-1B  
Center Opening VVVF Door Operator  
(Car Top Installation)

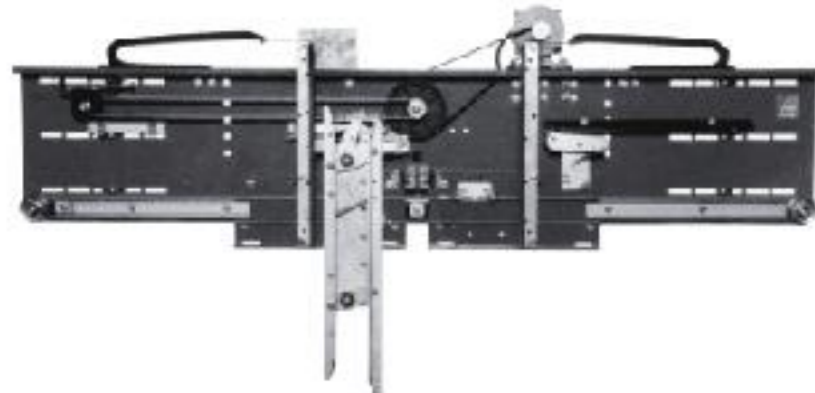

·GF-131-50A  
Center Opening VVVF Door Operator  
(Straight Beam Mounting)

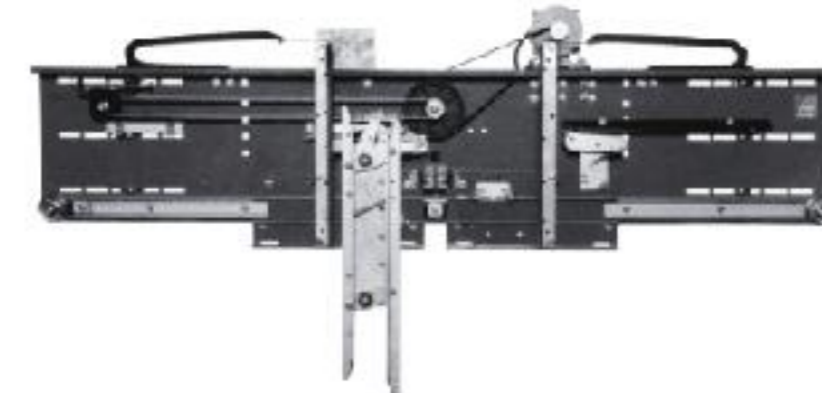

·GF-131-50B  
Center Opening VVVF Door Operator  
(Car Top Installation)

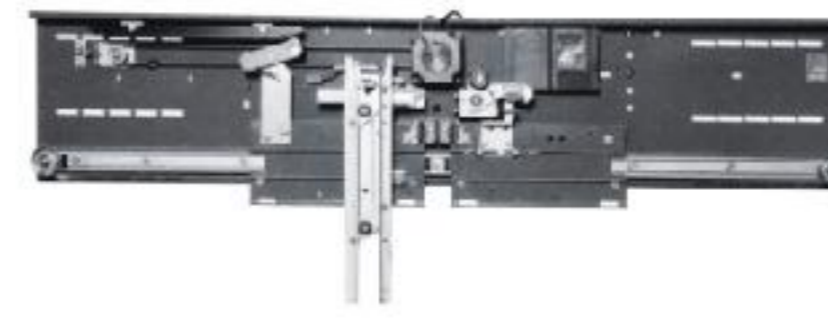

·GF-131-50-YC-A  
Center Opening AC PM Door Operator  
(Straight Beam Mounting)

## ▶ Mitsubishi Door Operator

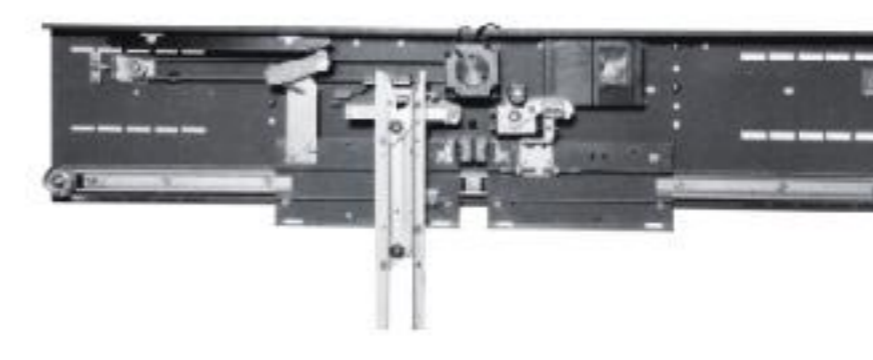

·GF-131-50-YC-B  
Center Opening AC PM Door Operator  
(Car Top Installation)



·GF-131-52A  
Side Opening VVVF Door Operator  
(Straight Beam Mounting)



·GF-131-52B  
Side Opening VVVF Door Operator  
(Car Top Installation)



·GF-131-53A  
3 Fold Next Door Operator  
(Straight Beam Mounting)



·GF-131-53B  
3 Fold Next Door Operator  
(Car Top Installation)



·GF-131-54A  
4 Panels Center Opening VVVF  
Door Operator (Straight Beam Mounting)



·GF-131-54B  
4 Panels Center Opening VVVF  
Door Operator (Car Top Mounting)



·GF-131-56A  
6 Panels Center Opening VVVF  
Door Operator (Straight Beam Mounting)



·GF-131-56B  
6 Panels Center Opening VVVF  
Door Operator (Car Top Installation)



·GF-161-50  
Center Opening Landing Door Mechanism

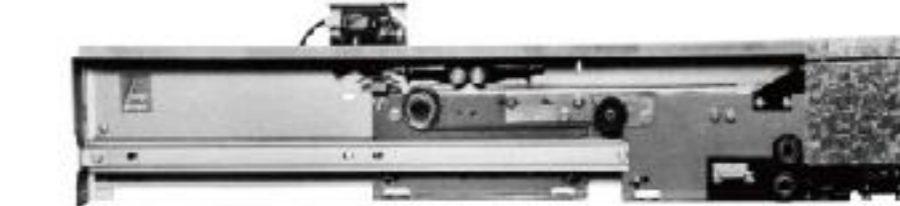

·GF-161-51  
Side Opening Landing Door Mechanism



·GF-161-52  
Side Opening Landing Door Device



► Mitsubishi Landing Door Hanger



·GF-161-53 Open Next Three Fold Door Device  
 ·GF-161-54 4 Panels Center Opening Landing Door Device  
 ·GF-161-56 3 Layered Gate Device Compromise

► Components for Door Operator of the Passenger Elevator



Inverter Inverter Inverter Inverter Inverter  
 Permanent Magnet Motor Motor(Asynchronous) Motor(Asynchronous) Belt Pulley Belt Pulley  
 Bearing Stand/Bearing/Driven Wheel Module Synchronous Belt Drive Wheel/Driven Wheel Module Belt Belt Belt  
 (With door lock function) Synchronous Door VaneModule (With door lock function) Door VaneModule Spring Bolt Module Door Vane/Connecting Rod  
 ø72 Pulley Guide Wheel Car Door Switch Contact Switch Electronic Bistable Switch Module

► Components for Landing Door Device of the Passenger Elevator

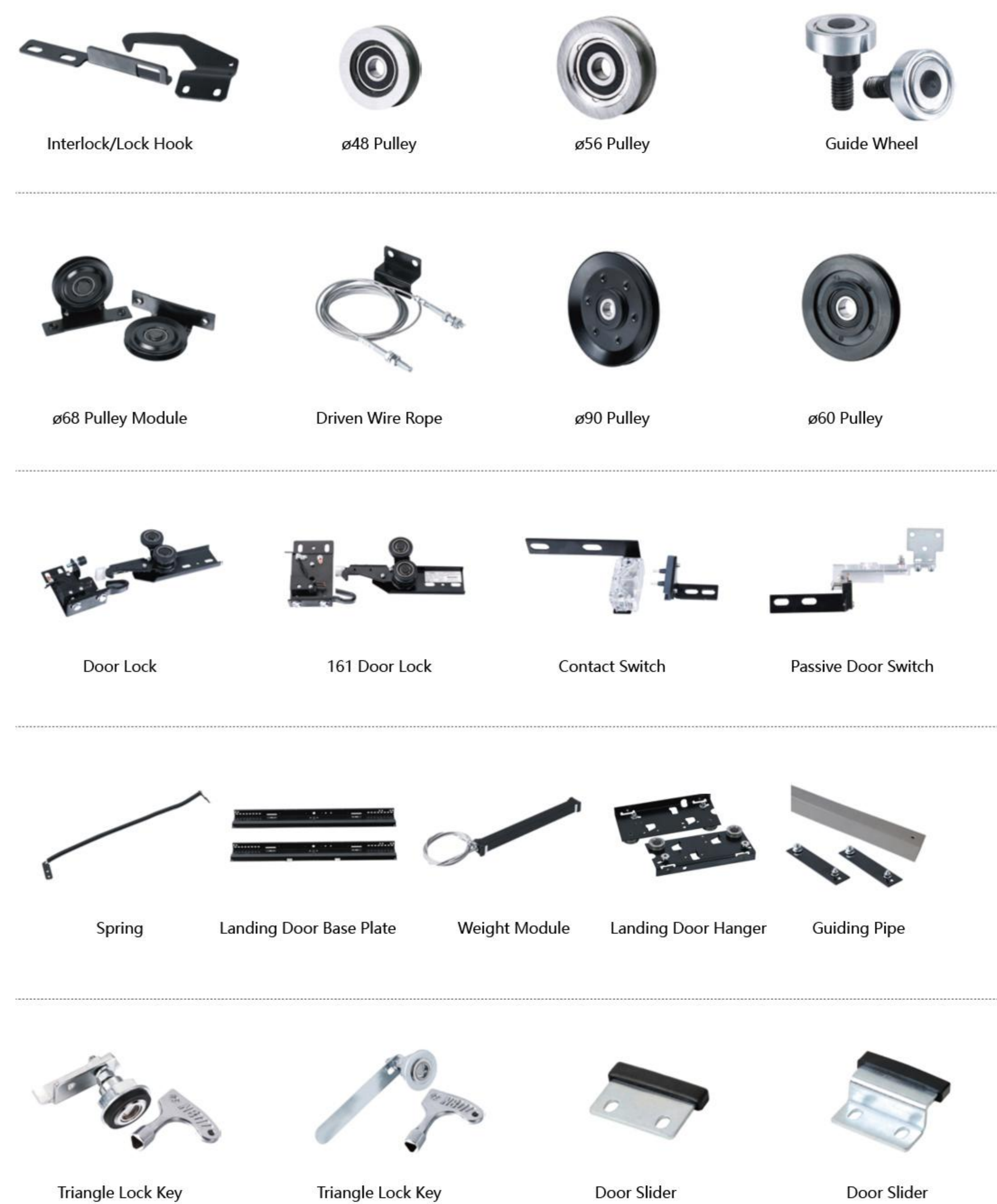

Interlock/Lock Hook ø48 Pulley ø56 Pulley Guide Wheel  
 ø68 Pulley Module Driven Wire Rope ø90 Pulley ø60 Pulley  
 Door Lock 161 Door Lock Contact Switch Passive Door Switch  
 Spring Landing Door Base Plate Weight Module Landing Door Hanger Guiding Pipe  
 Triangle Lock Key Triangle Lock Key Door Slider Door Slider



► Selcom Door Operator



·GF-ECO-02/C  
Two Panels Center Opening  
Car Door Operator

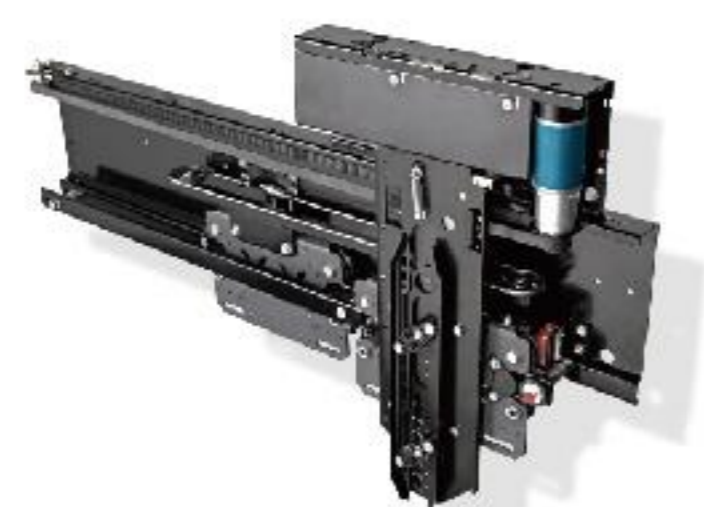

·GF-ECO-12/R-L  
Two Panels Telescopic Opening  
Car Door Operator



·GF-ECO-01C  
Two Panels Center Opening Landing Door



·GF-OSCAR-02/C  
Two Panels VVVF Center Opening  
Car Door Operator

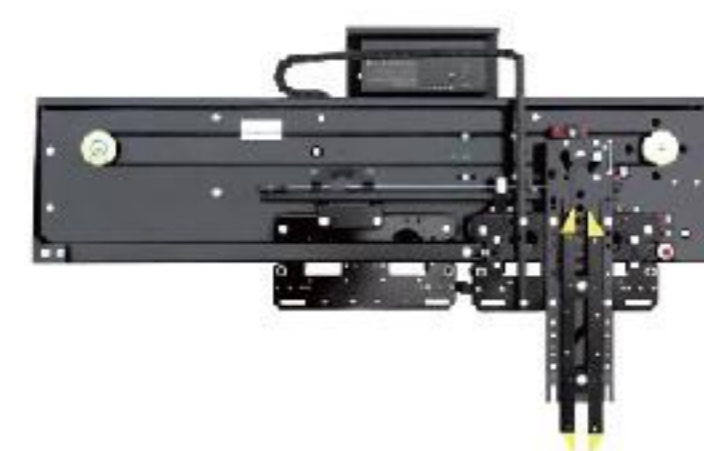

·GF-OSCAR-12/L-R  
Two Panels VVVF Telescopic Opening  
Car Door Operator



·GF-ECO-11/R-L  
Two Panels Telescopic Opening  
Landing Door

► Selcom Door Operator Accessories



Tooth Belt



Driven Steel Wire Rope



Contact Bridge



Door Contact(Square)



Door Contact(Oblong)



Closing Spring



Hanging Bolts Set



Top Roller



Plastic Top Roller



Rope Roller



Bottom Roller



Emergency Key



Bottom Shoes Set



Emergency Release



Poly V Belt



Door Lock Base



Cam



Panasonic Controller

► Fermator Door Operator



Side Opening Car Door



Side Opening Landing Door

► Elevator Light Curtain

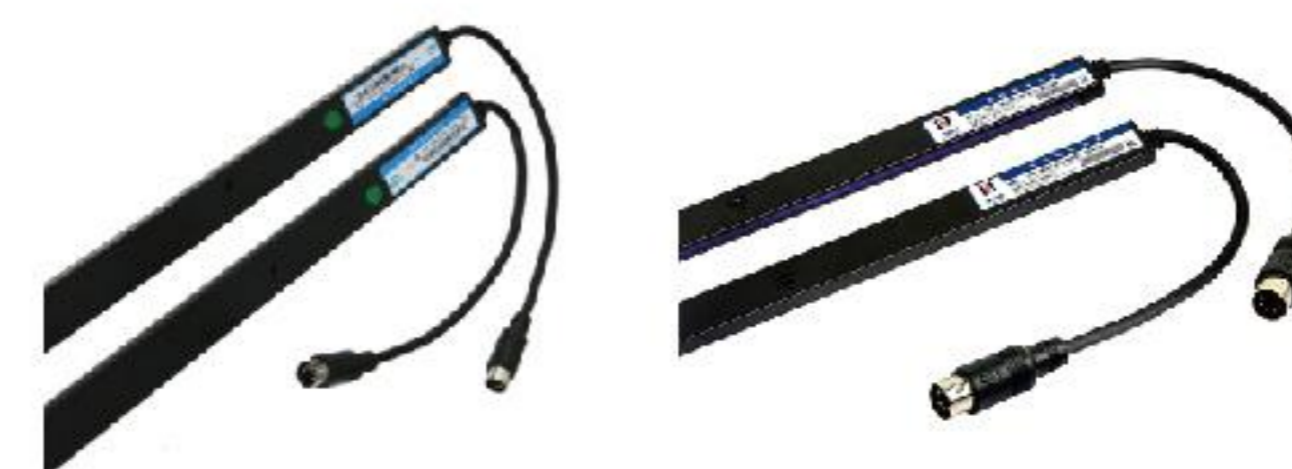

917A61

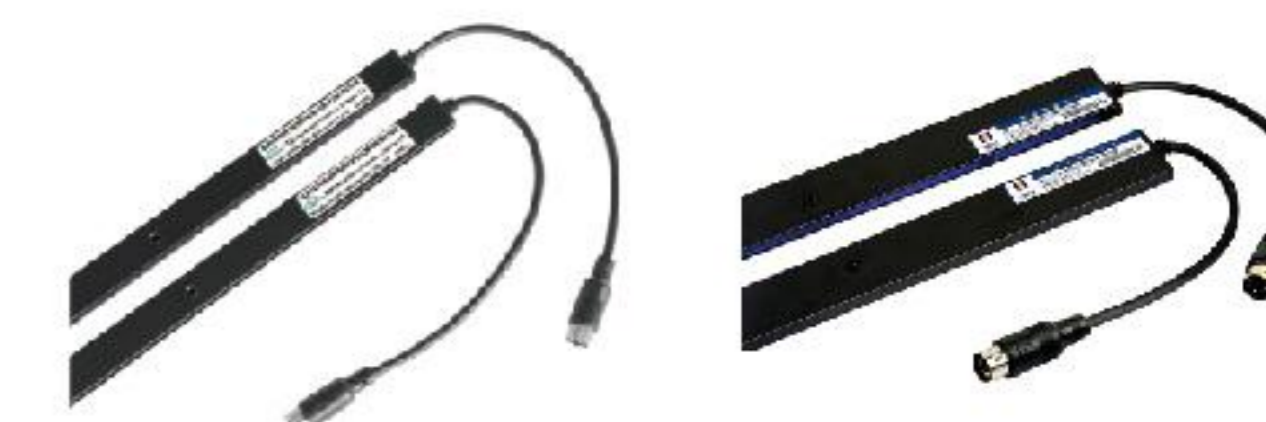

917B71

► Synchronous Belt & Synchronous Pulley





► Fireproof Door Operator Accessories

Teflon series

Teflon is also called polytetrafluoroethylene (PTFE). This series of products have excellent high temperature resistance, wear resistance, corrosion resistance, self-lubrication and excellent flame retardancy. They are the best choice for fire elevators and fire protection accessories.

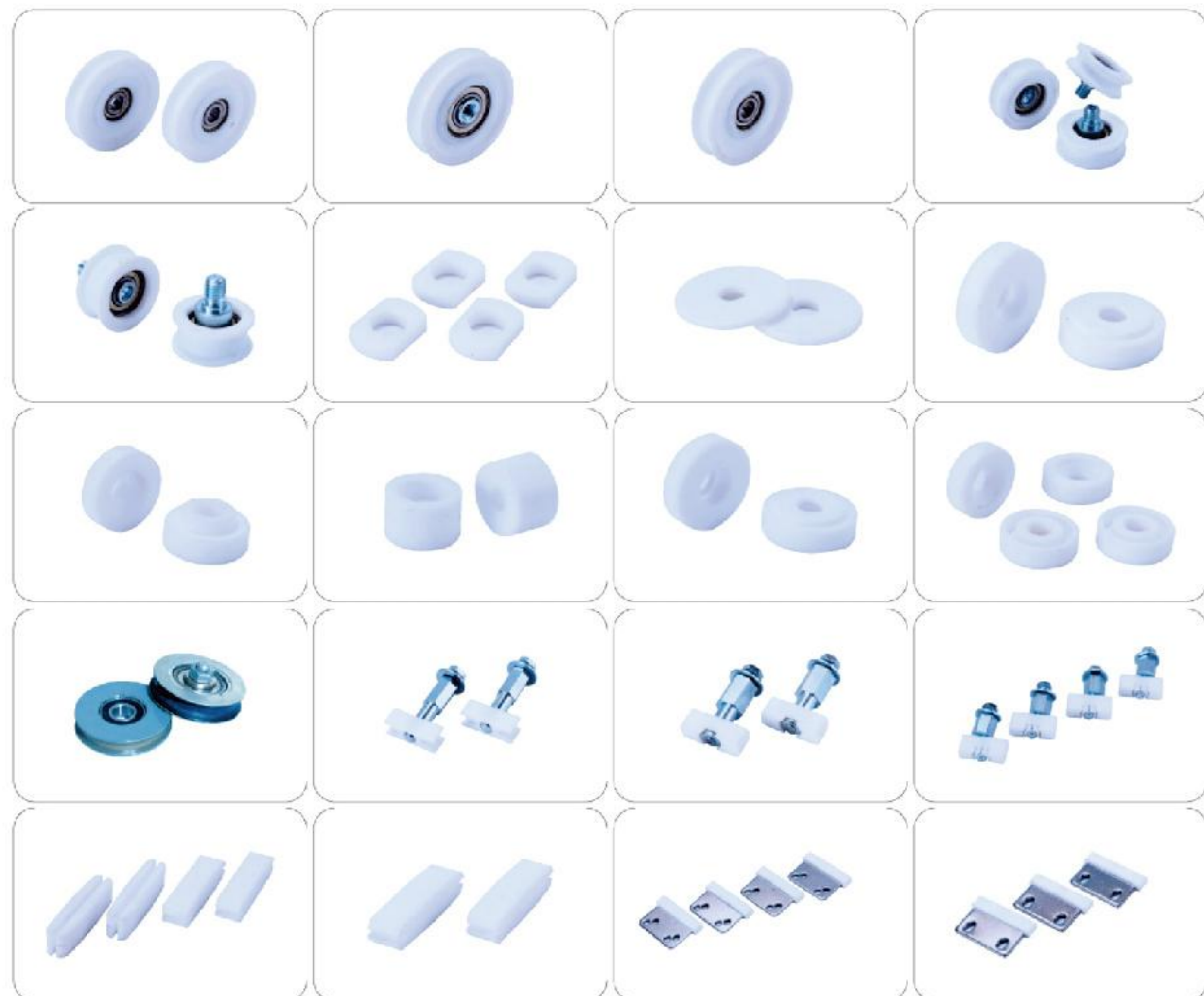

New patented product

Teflon coated iron rollers, this product inherits the fireproof performance of Teflon rollers. At the same time, when the rigid support is lost under the condition of Teflon ultra-high temperature, the iron groove can with back support.

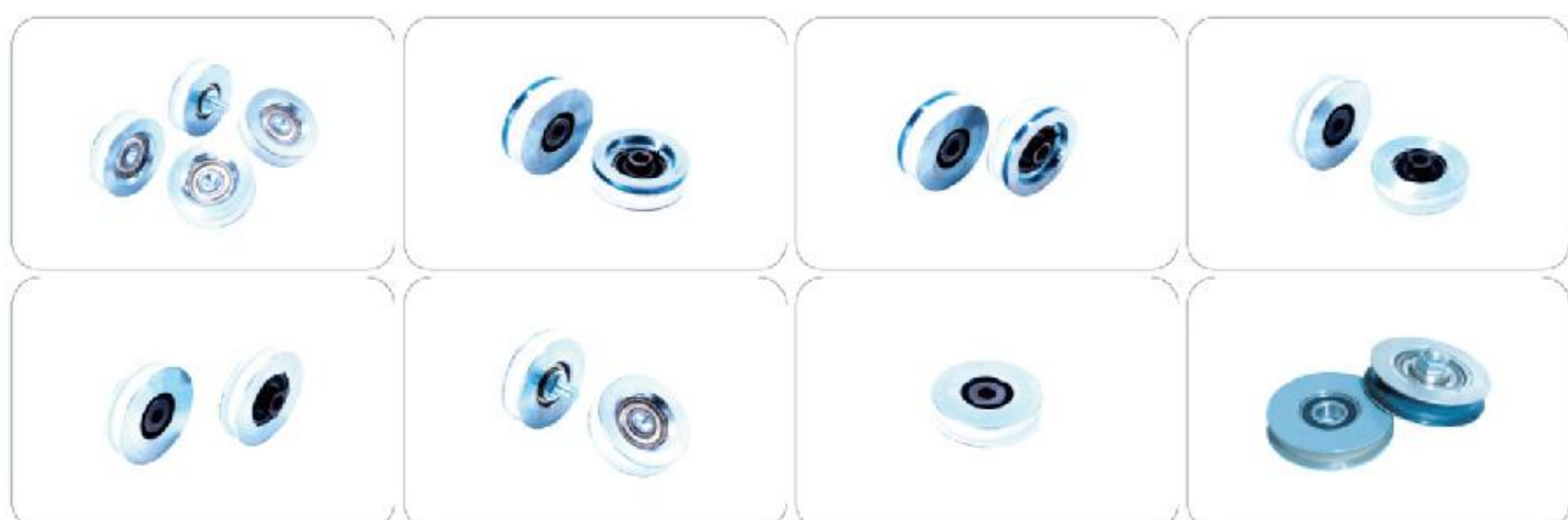

► Fireproof Accessories

Fireproof accessories, the rubber can meet the V-O fireproof rating and can provide excellent shock absorption under normal conditions.



► Conventional Door Operator Accessories



► Damping Pad



► Buffer Pad





# Electric System

- Elevator Controller
- Elevator Control Cabinet
- Weighing Measuring Device
- LOP Series
- COP Series
- Arrival Light Series
- Elevator Push Button Series
- Display Series
- Resistor
- Interphone
- Traveling Cable
- Limit Switch Series
- Encoder
- Photoelectric Switch
- Door Switch
- Oil Can
- Drive Pulley
- Elevator Fan
- IC System
- Elevator Parts

## ▶ Elevator Controller



·STEP-AS320



·STEP-AS360



·STEP-AS380



·STEP-AS330



NICE900



NICE1000



NICE3000



·Escalator controller



·EC300

## ▶ Elevator Control Cabinet



·STEP-MCP-ST/G 6400



·STEP-MCP-ST/G 2300



·STEP-MCP-ST/G 0100



·STEP-MCP-ST/B 6000



·STEP-CP-C7000



·MONARCH-NICE-CB1



·MONARCH-NICE-CE1



► Elevator Control Cabinet



·MONARCH-NICE-CF1



·MONARCH-NICE-CW1



·MONARCH-NICE-CX1



·Machine room control cabinet



·Machine roomless control cabinet



·Ville elevator control cabinet



·GF-ARD500



·GF-ARD3000T



·Escalator control cabinet



·GF-MTCC



·GF-EC100

► Weighing Measuring Device



·GF-MR100



·GF-MR200



·GF-MR300



·GF-EOM101

► LOP Series



·GF-BX-008



·GF-BX-008S



·GF-BX-BT-008S



·GF-XF-004



·GF-JZ-004



·GF-BX-051



·GF-BX-052



·GF-BX-053



·GF-BX-054



·GF-BX-038



·GF-BX-021



·GF-BX-018



·GF-BX-039



·GF-BX-041



·GF-BX-046



·GF-BX-011



·GF-BX-032



·GF-WH-001



·GF-WH-002



·GF-WH-003



·GF-WH-005



·GF-WH-009



·GF-WH-010



·GF-WH-013



·GF-WH-006



·GF-WH-007



·GF-WH-008



·GF-WH-011



·GF-WH-012



·GF-WH-015



·GF-WH-016



▶ COP Series



▶ Arrival Light Series

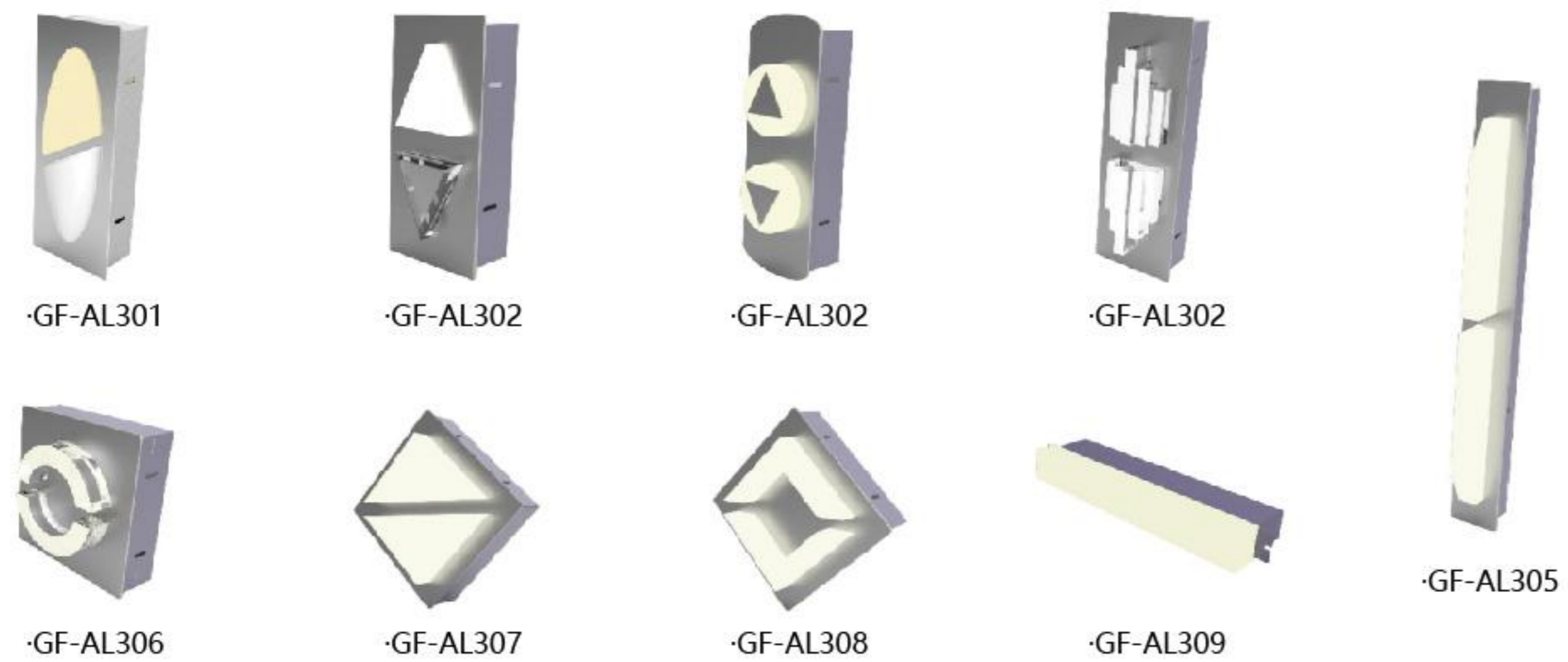

▶ Elevator Push Button Series

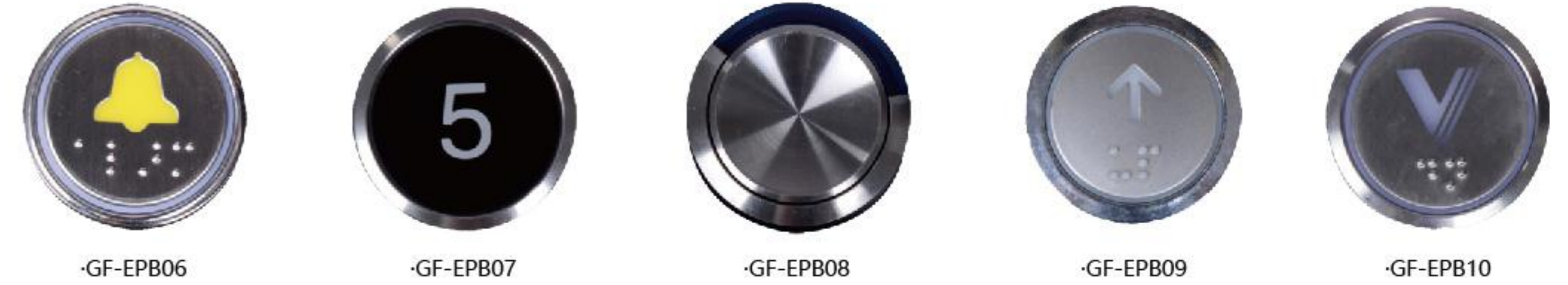



► Elevator Push Button Series

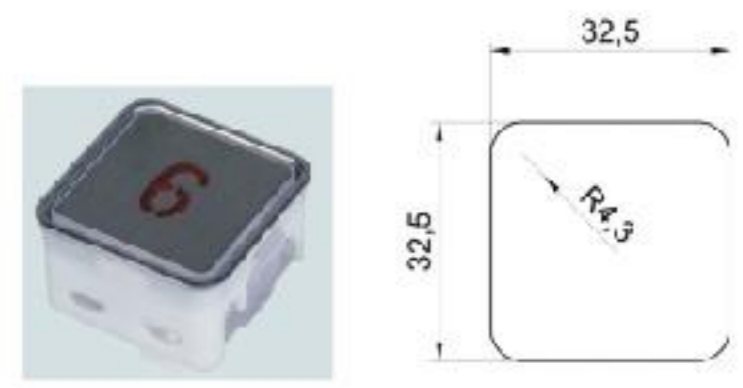

·GF-EPB270

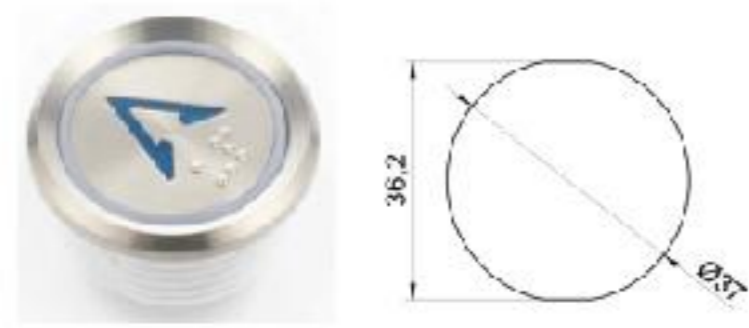

·GF-EPB122

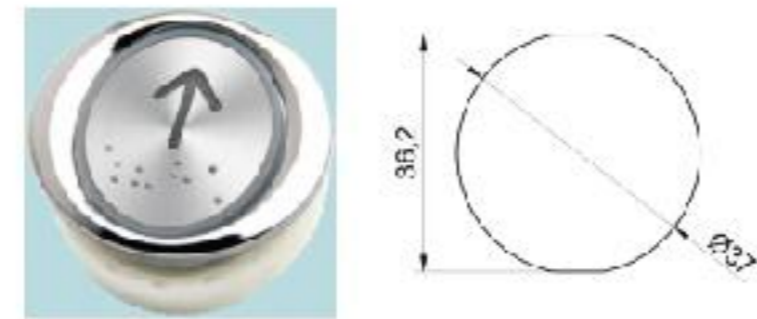

·GF-EPB123



·GF-EPB306



·GF-EPB318

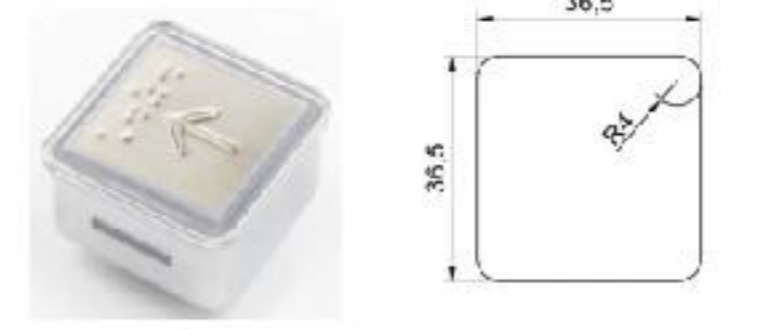

·GF-EPB117

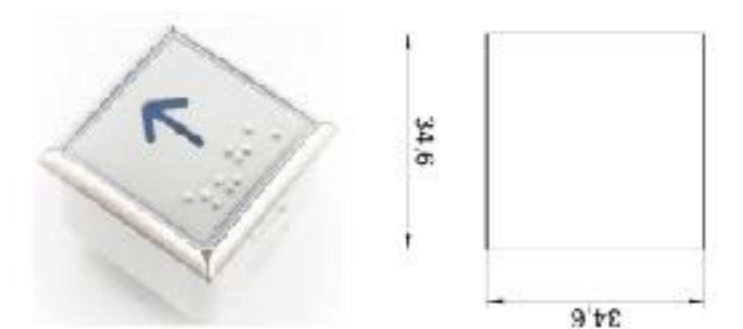

·GF-EPB413

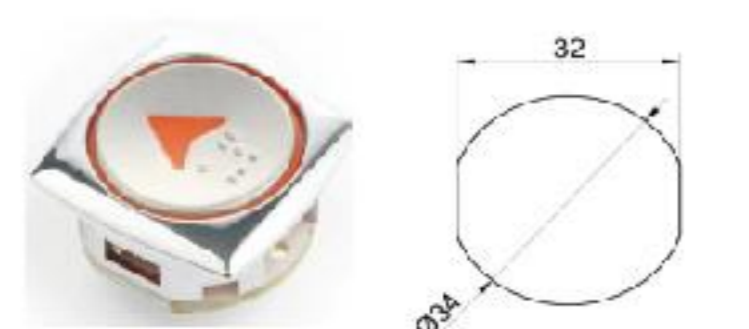

·GF-EPB040

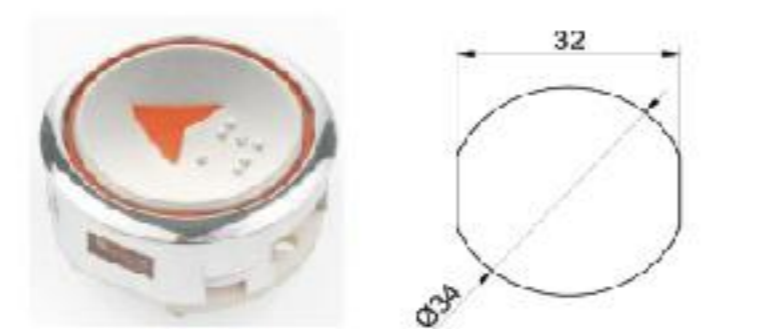

·GF-EPB041



·GF-EPB603



·GF-EPB322-F



·GF-EPB322-FS



·GF-EPB322-Y



·GF-EPB322-YS

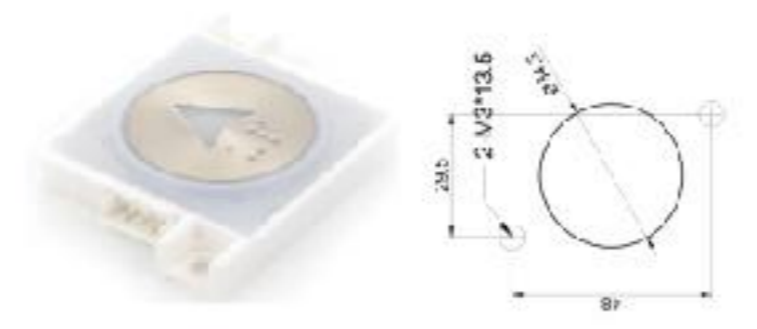

·GF-EPB013-Y

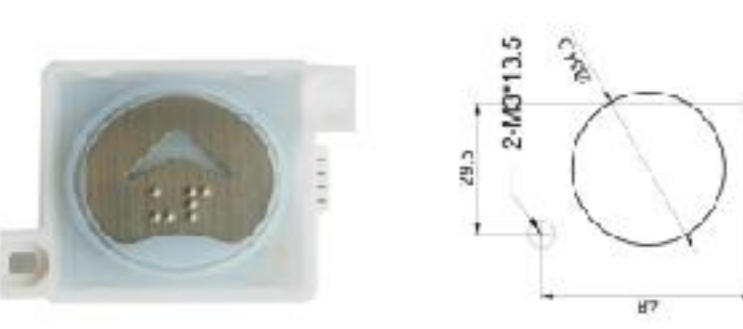

·GF-EPB013-UY

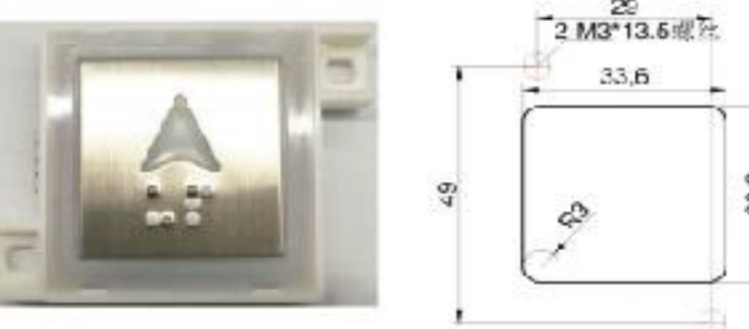

·GF-EPB013-F



·GF-EPB561

► Elevator Push Button Series



·GF-EPB124



·GF-EPB316



·GF-EPB305B-K



·GF-EPB320B



·GF-EPB111B

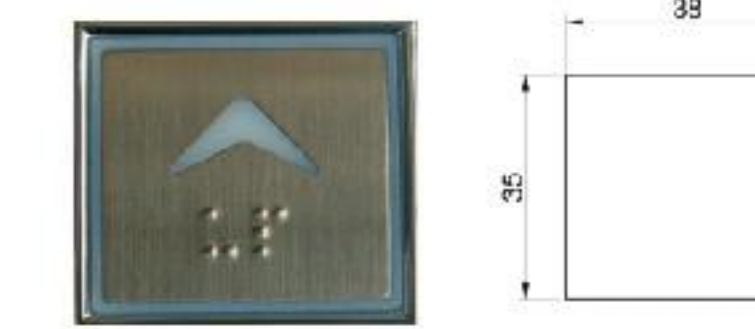

·GF-EPB630B



·GF-EPB2/1B



·GF-EPB273B



·GF-EPB630B

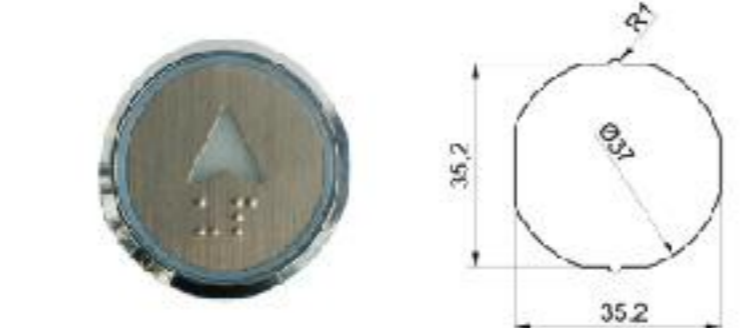

·GF-EPB313B-X

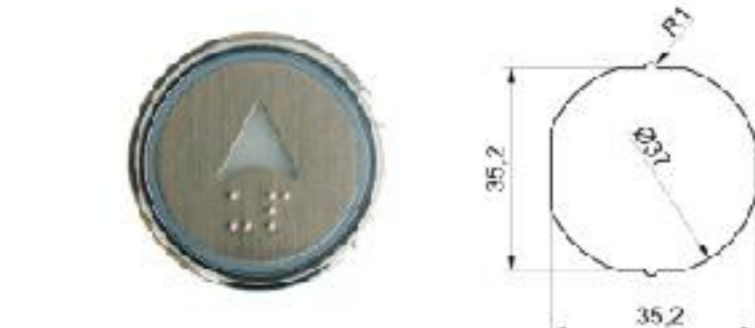

·GF-EPB313-O

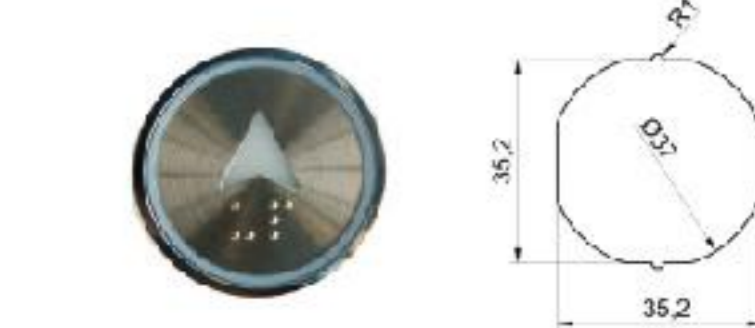

·GF-EPB313B-C

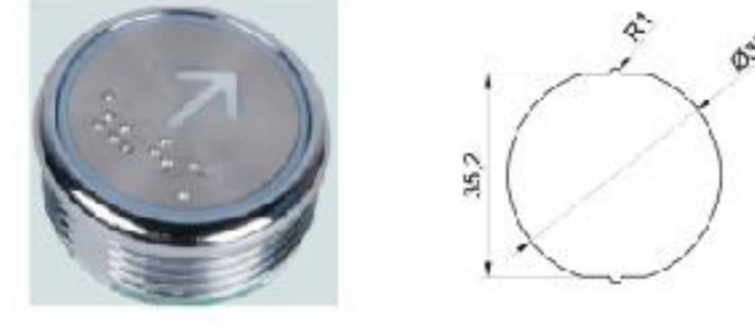

·GF-EPB313



·GF-EPB313C



·GF-EPB313B-YJD



·Round emergency light

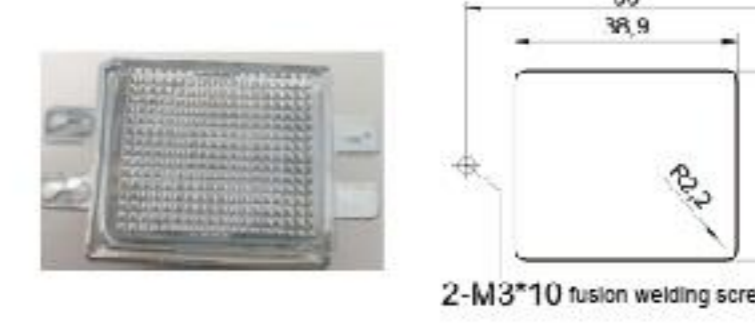

·Square emergency light

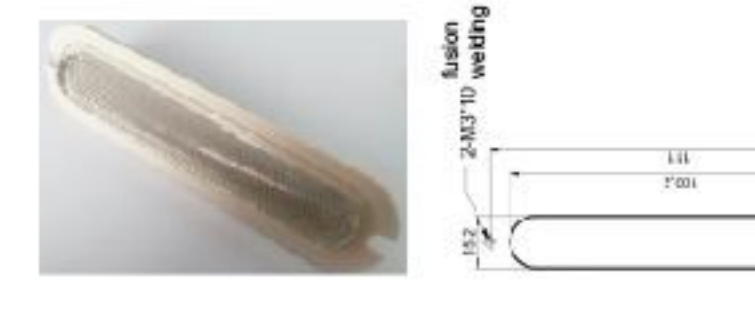

·Long emergency light



► BST Elevator Push Button Series

欧洲标准按钮

EN Standard Button



EN81-70 EN81-70 EN81-70 EN81-70 EN81-70 EN81-70  
MA1505 MA1L04 BAS241 MA1204 MA5304 MA1807

澳洲标准按钮

Australian Standard Button



EN81-70 EN81-70 EN81-70  
HA2S01 (IP54) 防撞 Anti-vandal  
MA2J03 (超薄) Ultra Thin Button  
MA2K01 (超薄) Ultra Thin Button  
超薄按钮厚度9mm。 Ultra Thin Button with 9mm Thickness.  
HA2S02  
HA2301 (IP05) 防撞1类梯 Anti-vandal

北美标准按钮

NA Standard Button



HA2003 HA2102 BAS141 BAS143 KAF291 KAF301

树脂按钮

Resin Button

高透明度，水晶质感  
High Transparency, Crystal Texture.



HA1T01 HA1T02 HA3501 MA3101 (超薄) (Ultra Thin Button) MA1C02 (超薄) (Ultra Thin Button) MA1B01 BAMSC001 (黑色透光按钮)

► BST Elevator Push Button Series

经济型按钮

Economic Button



KAS934 MA2D02 BAS10F MA1707

防撞按钮

Anti-vandal Button



HA1107 HA1007 MA2G01

组合按钮

Combination Button



HA2D02 (机械) HA2C02 (机械) HA2B01 (机械) HA2Z08 (感应) HA2Y02 (感应) HA2Y05 (感应)

感应按钮

Touch Button

触摸灵敏，性能稳定。  
Sensitive Touch, Stable Performance.



HA1513 HA1502 HA2U09 HA2U02

应急灯

Emergency Light



MA1B03 MA1C03

玻璃按钮

Glass Button



BAMFC001 BAMFC001 BAMFS001 BAMFS001

按钮锁

Key Button



KA301锁 BA540薄型锁



▶ STEP Display Series



▶ MONARCH Display Series

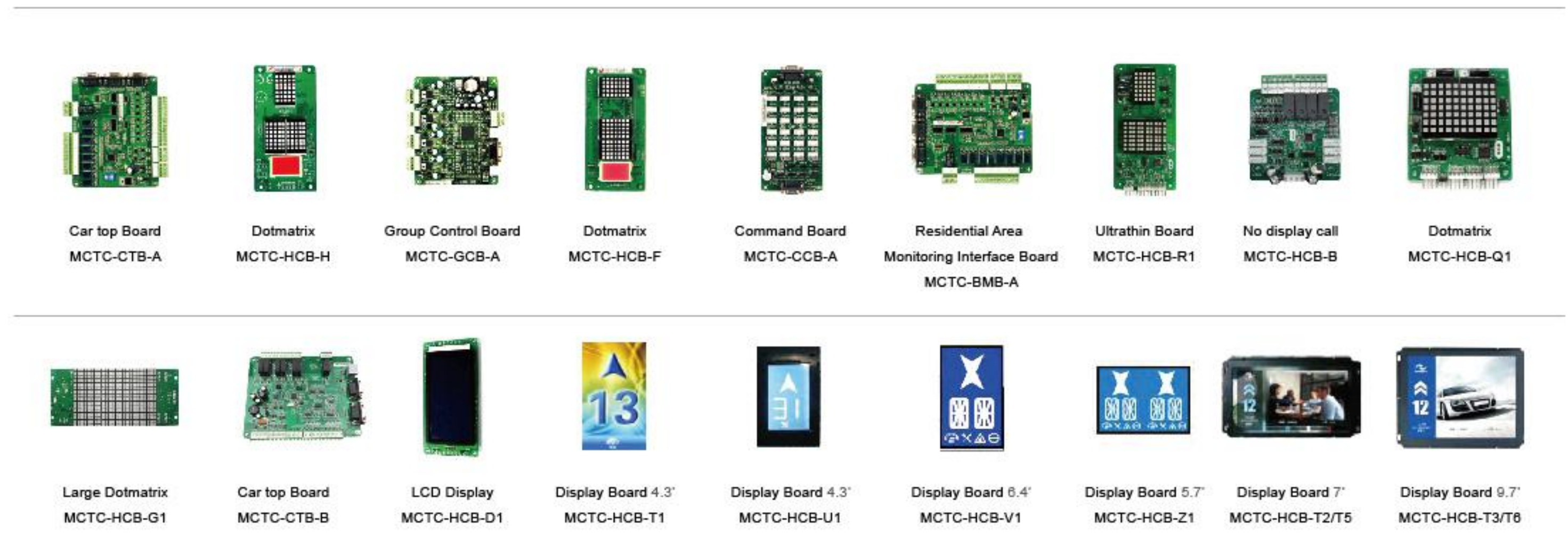

▶ Display Series



▶ Resistor



▶ Encoder



▶ Interphone



▶ Photoelectric Switch



▶ Traveling Cable

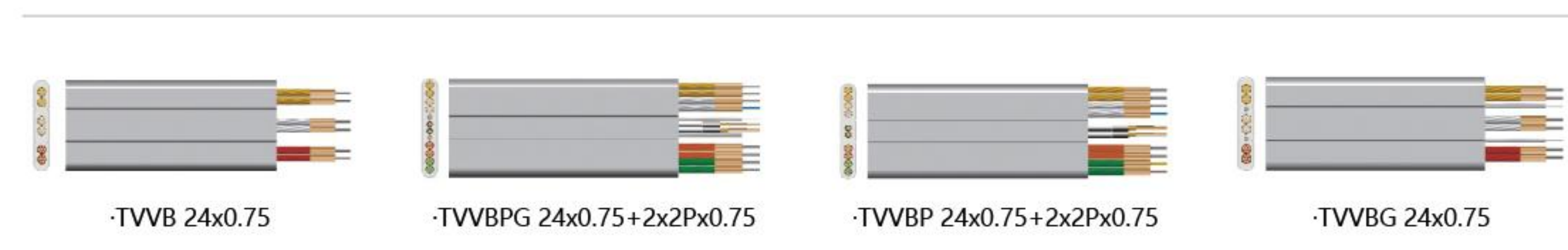

▶ Limit Switch Series





▶ Door Switch



▶ Oil Can



Cooperative Supplier



▶ Elevator Fan



▶ IC System



▶ Elevator Parts





# Traction System

- Traction Machine
- Rope Fastening
- Elevator Ropes
- Damping Pad
- Drive Pulley

## ► Economical Series For Passenger Elevator



·GF-MCK100  
Load:320-630kg  
Speed:0.5-1.75m/s



·GF-MCK200  
Load:630-1150kg  
Speed:0.5-2.5m/s



·GF-FRD21M  
Load:320-450kg  
Speed:0.4m/s



·GF-FRD32W  
Load:450-1050kg  
Speed:0.5-2.0m/s



·GF-FRD40E  
Load:1150-1600kg  
Speed:0.5-2.5m/s



·GF-FRD40W  
Load:630-1600kg  
Speed:0.5-2.0m/s



·GF-FRD45D  
Load:1150-2500kg  
Speed:0.5-3.0m/s



·GF-MONA320A  
Load:320-450kg  
Speed:0.5-1.0m/s



·GF-MONA320B  
Load:630-1000kg  
Speed:0.5-1.75m/s



·GF-FRD48  
Load:1600-3000kg  
Speed:0.5-3.0m/s



·GF-FRD40T  
Load:630-1000kg  
Speed:0.5-1.75m/s



·GF-B320/450  
Load:320-450kg  
Speed:0.5-1.75m/s



·GF-B630/1000  
Load:630-1000kg  
Speed:0.5-2.0m/s



·GF-B1150  
Load:800-1150kg  
Speed:0.5-2.5m/s



·GF-B1250  
Load:1250kg  
Speed:0.5-2.5m/s



·GF-P250/450  
Load:250-450kg  
Speed:0.4-0.5m/s



► General Series For Passenger Elevator



·GF-GTW3  
Load:1150-1350kg  
Speed:1.0-1.75m/s



·GF-GTW5A  
Load:1350-2000kg  
Speed:0.5-2.0m/s



·GF-GTW7A  
Load:320-630kg  
Speed:0.63-1.75m/s



·GF-GTW9S  
Load:630-1150kg  
Speed:1.0-2.0m/s



·GF-WJC  
Load:320-1250kg  
Speed:1.0-2.5m/s



·GF-WTY1  
Load:320-800kg  
Speed:1.0-2.0m/s



·GF-WRH  
Load:450-1000kg  
Speed:1.0-1.75m/s



·GF-WTY2  
Load:1600-2000kg  
Speed:1.0-2.5m/s

► Premium Series For Passenger Elevator



·GF-GETM1.9D  
Load:400kg  
Speed:0.4m/s



·GF-GETM6.0H  
Load:1000-2000kg  
Speed:1.0-3.0m/s



·GF-GETM3.0H(630kg)  
Load:630kg  
Speed:1.0-1.75m/s



·GF-GETM3.0H(800-1000kg)  
Load:800-1000kg  
Speed:1.0-1.75m/s



·GF-WSG09  
Load:630-1050kg  
Speed:1.0-2.0m/s



·GF-WSG-S1  
Load:360-750kg  
Speed:0.5-1.75m/s



·GF-WSG-S2.2  
Load:800-1350kg  
Speed:0.5-2.0m/s



·GF-WSG-TR  
Load:630-1000kg  
Speed:0.5-1.6m/s

► Economical Series For Freight Elevator



·GF-TMYJ135  
Load:300-630kg  
Speed:0.63-1.0m/s



·GF-TMYJ150K  
Load:500-630kg  
Speed:0.3-1.0m/s



·GF-TMYJ210  
Load:1000-2000kg  
Speed:0.25-1.0m/s



·GF-TMYJ210F  
Load:630-2000kg  
Speed:0.5-1.0m/s



·GF-TMYJ300  
Load:2500-8000kg  
Speed:0.25-1.0m/s



·GF-TMYJ350  
Load:2000-28000kg  
Speed:0.25-2.0m/s



·GF-YJ80  
Load:100-350kg  
Speed:0.35-0.8m/s



·GF-YJ100  
Load:320-408kg  
Speed:0.5-1.0m/s

► General Series For Freight Elevator



·GF-YJ125  
Load:400kg  
Speed:0.65-1.0m/s



·GF-YJ200A  
Load:630-1000kg  
Speed:0.5-2.0m/s



·GF-YJ320A  
Load:2000-2500kg  
Speed:0.5-2.0m/s



·GF-YJ410  
Load:5000-5500kg  
Speed:1.0-2.0m/s

► Premium Series For Freight Elevator



·GF-YJ160  
Load:630-1000kg  
Speed:0.63-1.6m/s



·GF-YJ240  
Load:750-3000kg  
Speed:0.63-2.0m/s



·GF-YJ245  
Load:1000-2000kg  
Speed:0.5-1.0m/s



·GF-YJ360  
Load:1000-5000kg  
Speed:0.63-2.5m/s



► Home Elevator Traction Machine Series



·GF-FRD21E  
Load:320-630kg  
Speed:0.4m/s



·GF-FRD21G  
Load:320-450kg  
Speed:0.4m/s



·GF-FRD32E  
Load:450-1050kg  
Speed:0.5-1.75m/s



·GF-FRD32G  
Load:320-630kg  
Speed:0.5-1.75m/s



·GF-FRD10G  
Load:320-450kg  
Speed:0.4m/s



·GF-FRD10GD  
Load:320-450kg  
Speed:0.4m/s

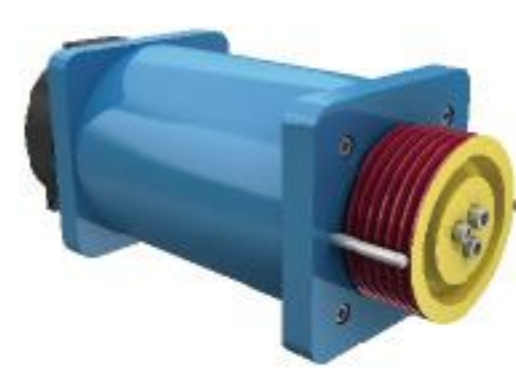

·GF-FRD15  
Load:320-450kg  
Speed:0.4m/s(Speed can be customized)



·GF-FRD16M  
Load:320-450kg  
Speed:0.4m/s



·GF-FRD18S  
Load:320-450kg  
Speed:0.4m/s



·GF-FRD21AX  
Load:320-450kg  
Speed:0.4m/s(Speed can be customized)



·GF-FRD32D  
Load:450-1050kg  
Speed:0.5-1.75m/s



·GF-FRD40D  
Load:630-1050kg  
Speed:0.5-2.5m/s

► Home Elevator Belt Traction Machine Series



·GF-FAXI80S  
Load:250-400kg  
Speed:0.3-0.4m/s



·GF-FAXI160XB  
Load:320-630kg  
Speed:0.3-1.0m/s



·GF-FAXI268  
Load:600-1000kg  
Speed:0.3-0.4m/s



·GF-FXW  
Load:630-1050kg  
Speed:1.0-2.0m/s

► Belt Traction Machine



·GF-GDX132  
Load:630-2000kg  
Speed:0.63-2.0m/s



·GF-GDX112-400  
Load:400kg  
Speed:0.4-1.0m/s



·GF-GDX112-480  
Load:480kg  
Speed:0.4-1.0m/s



·GF-GDX112-630  
Load:630kg  
Speed:0.4-1.0m/s

► Accessories



Counter Pulley



Brake Release



Belt Breaking Detect



Belt Lock



Weight Device



Grooved Belt



Smooth Belt



Belt Clip

► Traction Machine



·Escalator drive main engine

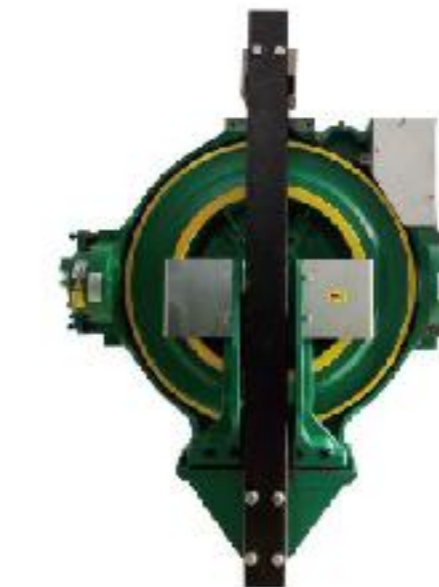

·GF-DA06

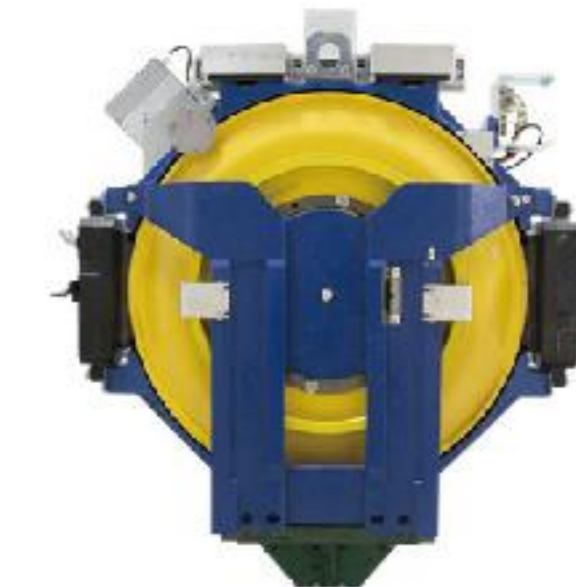

·GF-DA10



·GF-DA20



▶ Rope Fastening Series



Spring Rope Fastening



Rubber Rope Fastening



Flexible Rope Fastening

▶ Elevator Ropes Overview

6×19S+FC	6×19W+FC	6×25Fi+FC	6×29Fi+FC	6×36WS+FC
8×19S+FC	8×19W+FC	8×25Fi+FC	8×19S+IWRC	8×19W+IWRC
8×25Fi+IWRC	8×19S+IWRF	8×19W+IWRF	8×25Fi+IWRF	8×19S+IWRF
8×19S+PWRC	8×19W+PWRC	8×21Fi+PWRC	8×25Fi+PWRC	
9×17S+IWRC	9×19S+IWRC	9×19W+IWRC	9×21Fi+IWRC	9×25Fi+IWRC
9×17S+IWRF	9×19S+IWRF	9×19W+IWRF	9×21Fi+IWRF	9×25Fi+IWRF

▶ Damping Pad Series



·GF-S01



·GF-S02

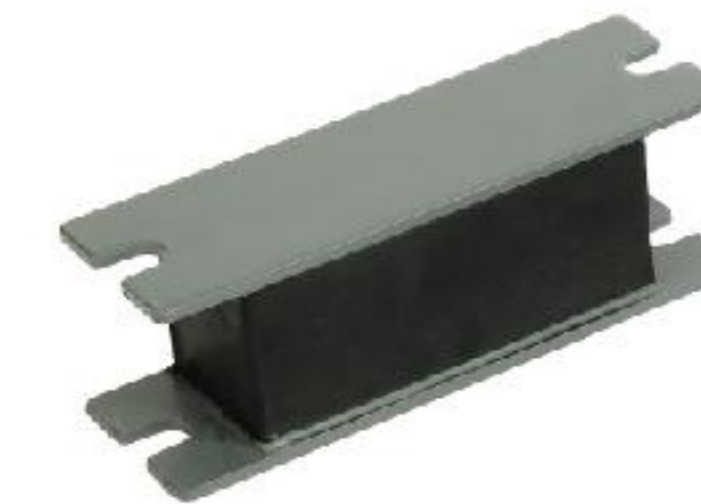

·GF-S03



·GF-S04



·GF-S05



·GF-S06



·GF-S07



·GF-S08

▶ Drive Pulley Series



Steel Core Guide Pulley



Cast Iron Pulley



Secondary Pulley



# Guide Rail And Balance System

- Roller Guide Shoe
- Sliding Guide Shoe
- Shoe Lining Series
- Guide Rail
- Compensating Chain
- Damping Device
- Counter Weight

## ▶ Roller Guide Shoe



GF-X01



GF-X02



GF-X03



GF-X06



GF-H01



GF-H02



GF-H05



GF-H07



GF-H08



GF-H09



GF-H22



GF-H25



GF-OX19



GF-H06(Φ70A)



GF-H06(Φ70B)



GF-H06(Φ55)



GF-H06(Φ70J)



GF-H06(Φ80J)



GF-H06(Φ100)



GF-H06(Φ100J)



▶ Sliding Guide Shoe



GF-SGS-X01

Rated speed: ≤2.0m/s

Width of guide rails: 9/10/16mm



GF-SGS-H03

Rated speed: ≤2.5m/s

Width of guide rails: 10/15.88/16mm



GF-SGS-H04

Rated speed: ≤1.75m/s

Width of guide rails: 9/10/15.88/16mm



GF-SGS-H14

Rated speed: ≤1.75m/s

Width of guide rails: 5/10/16.4mm



GF-SGS-H17

Rated speed: ≤1.75m/s

Width of guide rails: 5/9/10/15.88/16mm



GF-SGS-H27

Rated speed: ≤2.5m/s

Width of guide rails: 10/16mm



GF-SGS-KX04

Rated speed: ≤1.75m/s

Width of guide rails: 10/18mm



GF-SGS-YG031

Rated speed: ≤1.75m/s

Width of guide rails: 10/16.4mm

▶ Shoe Lining Series



230\*(10/16)



120\*(5/9/10/16)



140\*(9/10/16)



100\*(5/10/16)



220\*(10/16)



200\*(10/16)



10/16

▶ Guide Rail



Solid Rail



Hollow Rail



Solid Pressure Guides



Hollow Connecting Plate



Solid Connecting Plate



T-pressing Guides



Fitting

▶ Compensating Chain



GF-WFBS



GF-WFQS



GF-WFQS



GF-WFT-1

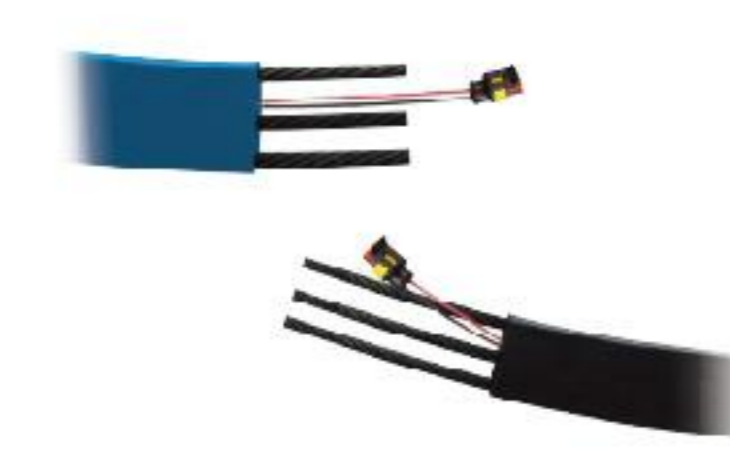

GF-WFT-2



S Hook



U Bolt



Hook



Mesh cable grip

▶ Damping Device



A type



B type



C type

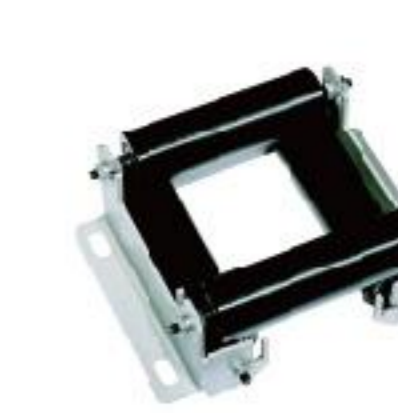

D type



E type

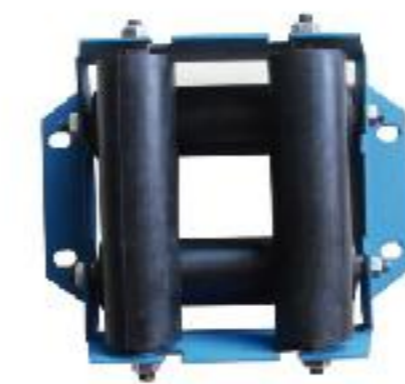

F type



G type



H type



Q type



I type

▶ Counter Weight



Compound Counterweight



Cast Iron Counterweight



Steel Counterweight



# Safety Components

- Safety Gear
- Speed Governor
- Inspection Box
- Buffer
- ARD
- Synchronous Belt & Synchronous Pulley

## ▶ Safety Gear



·GF-L01

Rated speed:≤2.5m/s



·GF-L02

Rated speed:≤0.63m/s



·GF-L03

Rated speed:≤2.5m/s



·GF-L05

Rated speed:≤0.63m/s



·GF-L06

Rated speed:≤1.75m/s



·GF-L07

Rated speed:≤0.63m/s



·GF-AQ10

Rated speed:≤2.5m/s



·GF-AQ10A

Rated speed:≤2.5m/s



·GF-AQZII

Rated speed:≤0.63m/s



·GF-JAQ4A

Rated speed:≤0.63m/s



·GF-D01

Rated speed:≤2.5m/s



·GF-D02

Rated speed:≤0.63m/s



·GF-D03

Rated speed:≤2.5m/s



·GF-D04

Rated speed:≤2.5m/s



·GF-AH01Z

Rated speed:≤0.63m/s



·GF-AH02Z

Rated speed:≤0.63m/s



·GF-AH03Z

Rated speed:≤0.63m/s



·GF-AH04

Rated speed:≤0.63m/s



·GF-AH06

Rated speed:≤0.63m/s



▶ Speed Governor



·GF-LOG01



·GF-LOG02



·GF-XS240



·GF-OX187



·GF-OX186A



·GF-OX240B



·GF-OX240F



·GF-S2Y



·GF-ZJ240

▶ Inspection Box



▶ Buffer



·OH10 ·OH16 ·OH20 ·OH65 ·OH70 ·OH80 ·OH175 ·OH210 ·OH220 ·OH275 ·OH425



▶ ARD



·GF-HCYD



·GF-3000T



·GF-500



·GF-TPS



·GF-EPD490



·GF-EPD500



·GF-61

·GF-71



# Cabin System

- Cabin
- Ceiling
- Car Floor
- Car Handrail
- Landing Door Series
- Semi-Automatic Elevator Door System



## ► High-end Business Series



·GF-K002



·GF-K003



·GF-K004



·GF-K005



·GF-K008



·GF-K009



·GF-K034



·GF-K035



·GF-K036



·GF-K037

## ► Extravagant Atmosphere Series



·GF-K055



·GF-K056



·GF-K057



·GF-K058



·GF-K067



·GF-K068



·GF-K069



·GF-K070



·GF-K087



·GF-K088



► Modern Concise Series

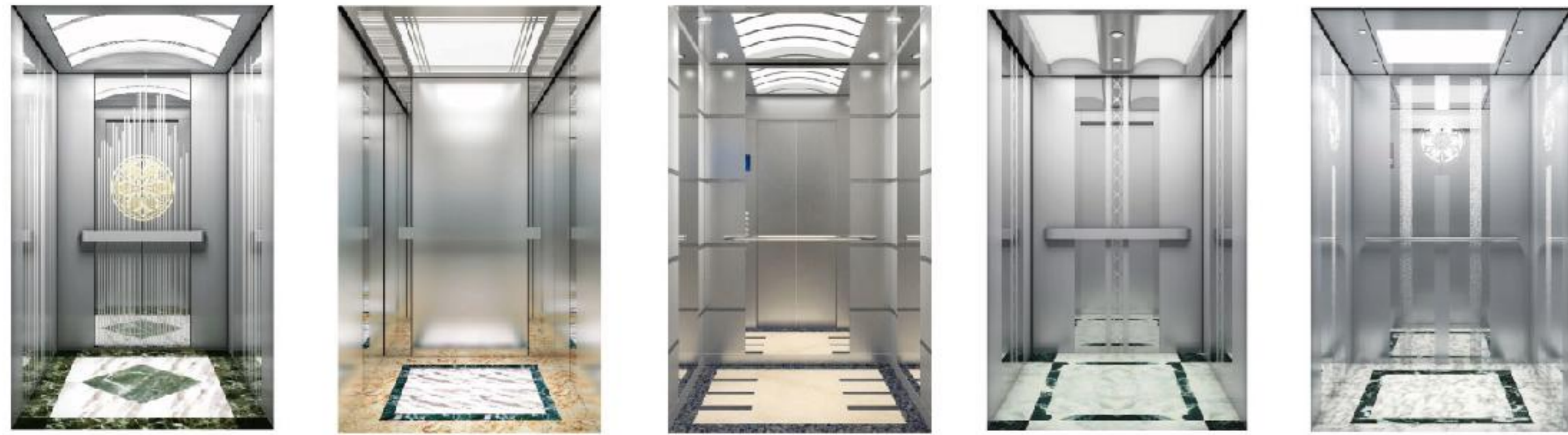

·GF-K092    ·GF-K093    ·GF-K094    ·GF-K095    ·GF-K096



·GF-K097    ·GF-K098    ·GF-K099    ·GF-K118    ·GF-K119

► Warm Household Series



·GF-V002    ·GF-V003    ·GF-V004    ·GF-V005    ·GF-V006



·GF-V007    ·GF-V008    ·GF-V009    ·GF-V012    ·GF-V013

► Luxury Sightseeing Series



·GF-G001    ·GF-G002    ·GF-G003    ·GF-G004    ·GF-G005



·GF-G006    ·GF-Y001    ·GF-Y002

► Ceiling Series



·GF-D001    ·GF-D002    ·GF-D003    ·GF-D004    ·GF-D005  
·GF-D006    ·GF-D007    ·GF-D008    ·GF-D009    ·GF-D010  
·GF-D011    ·GF-D012    ·GF-D013    ·GF-D014    ·GF-D015  
·GF-D033    ·GF-D034    ·GF-D041    ·GF-D043    ·GF-D044



► Handrail Series

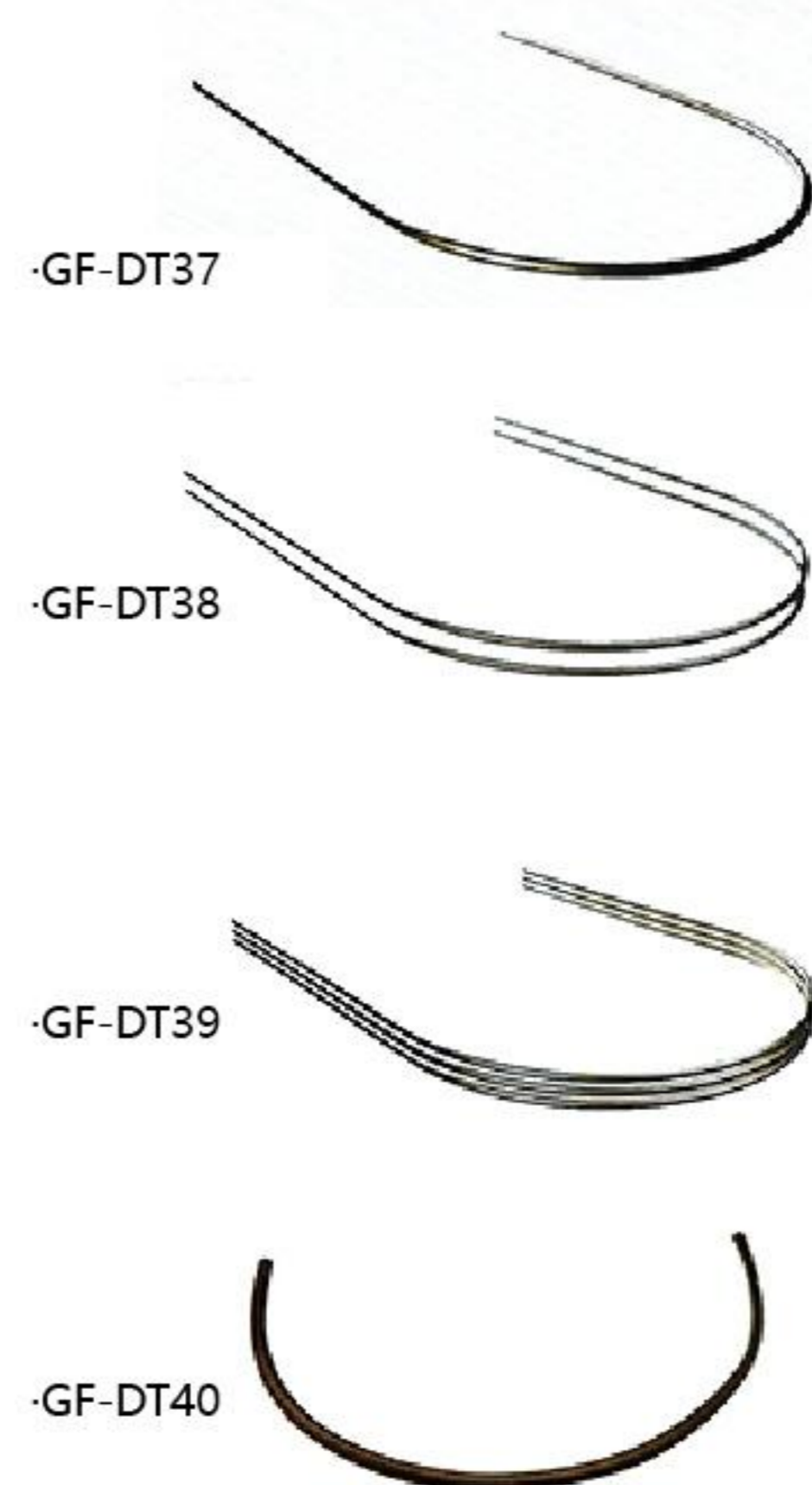
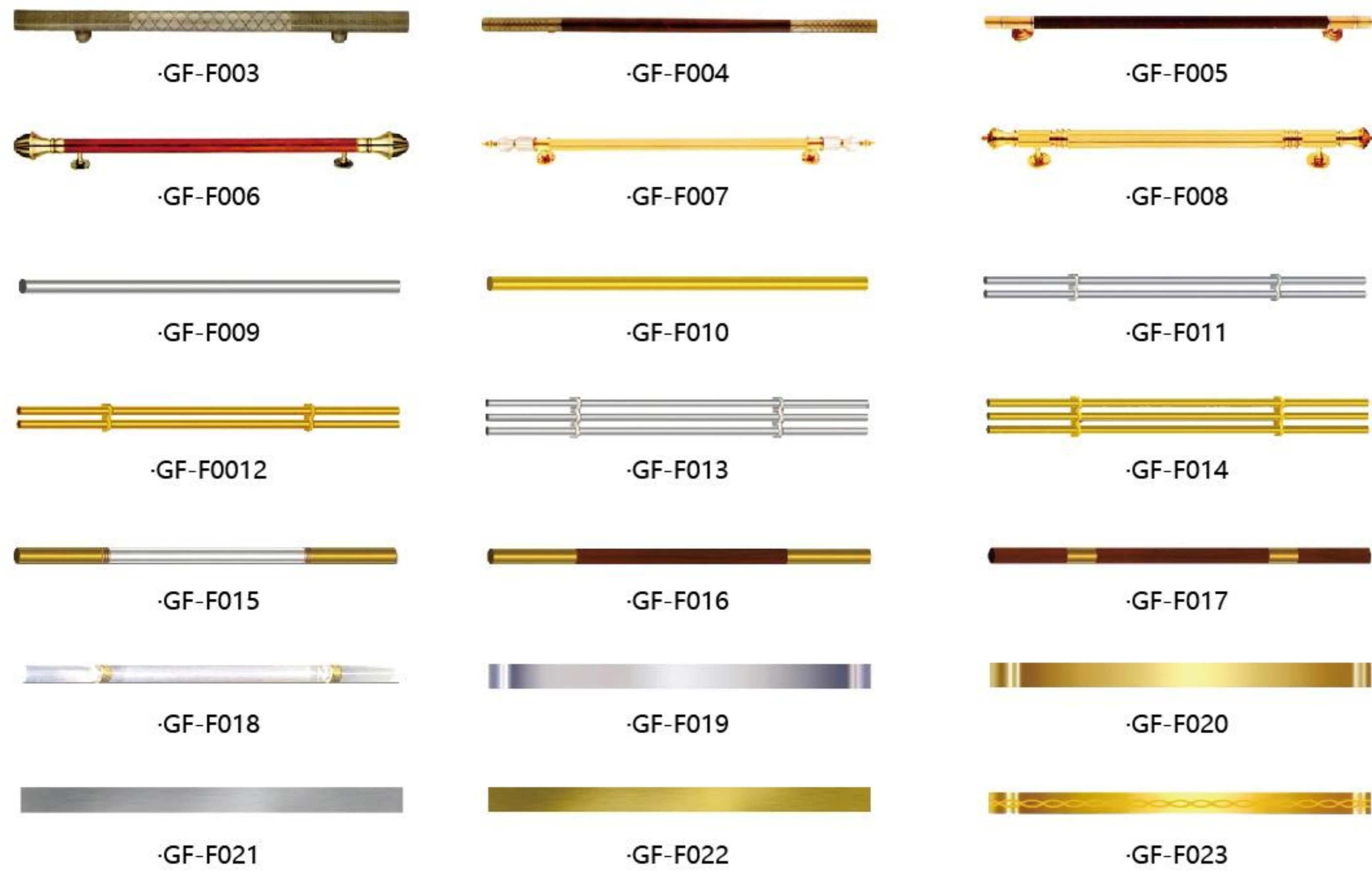

► Floor Series-Customization Series

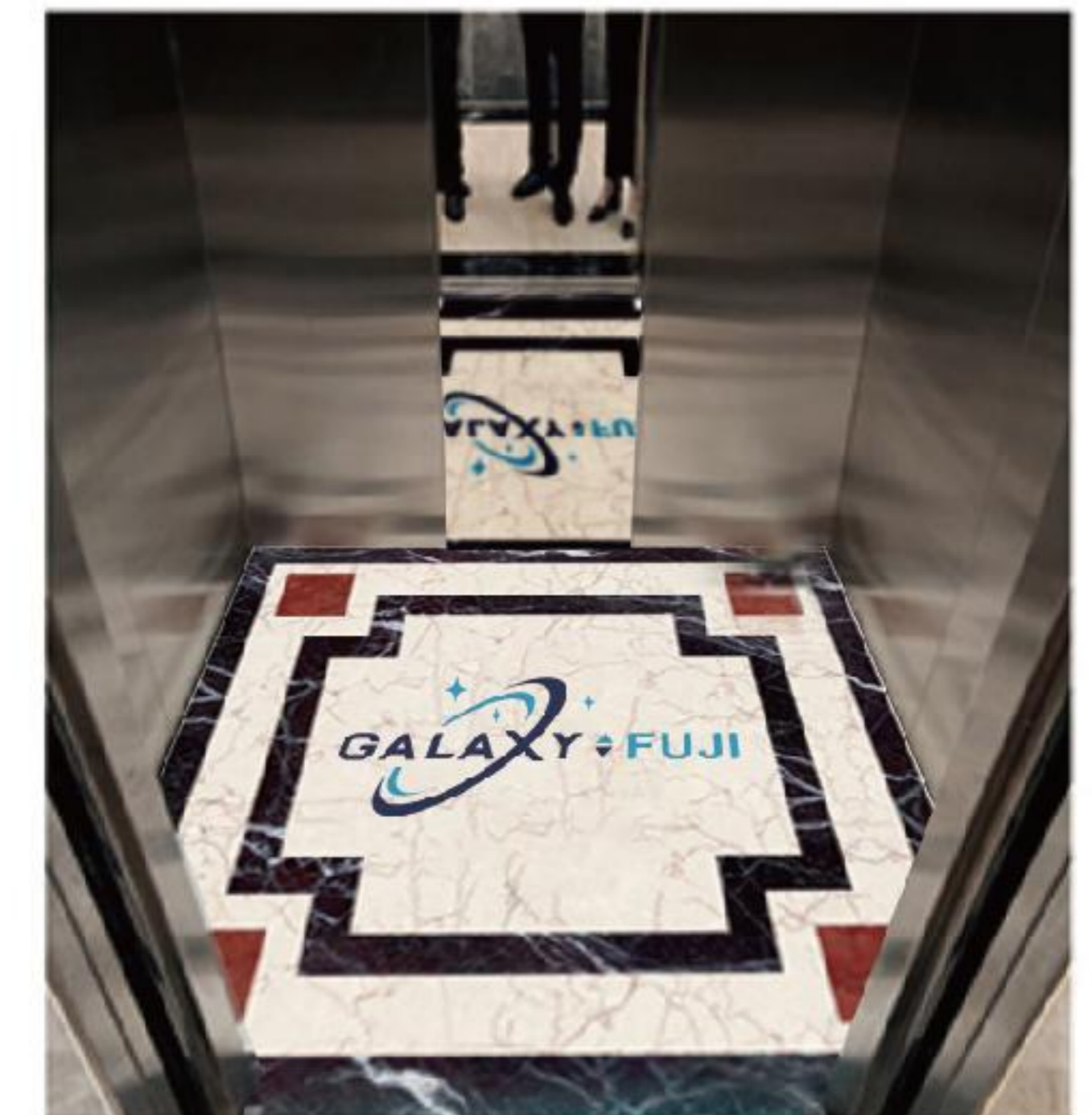
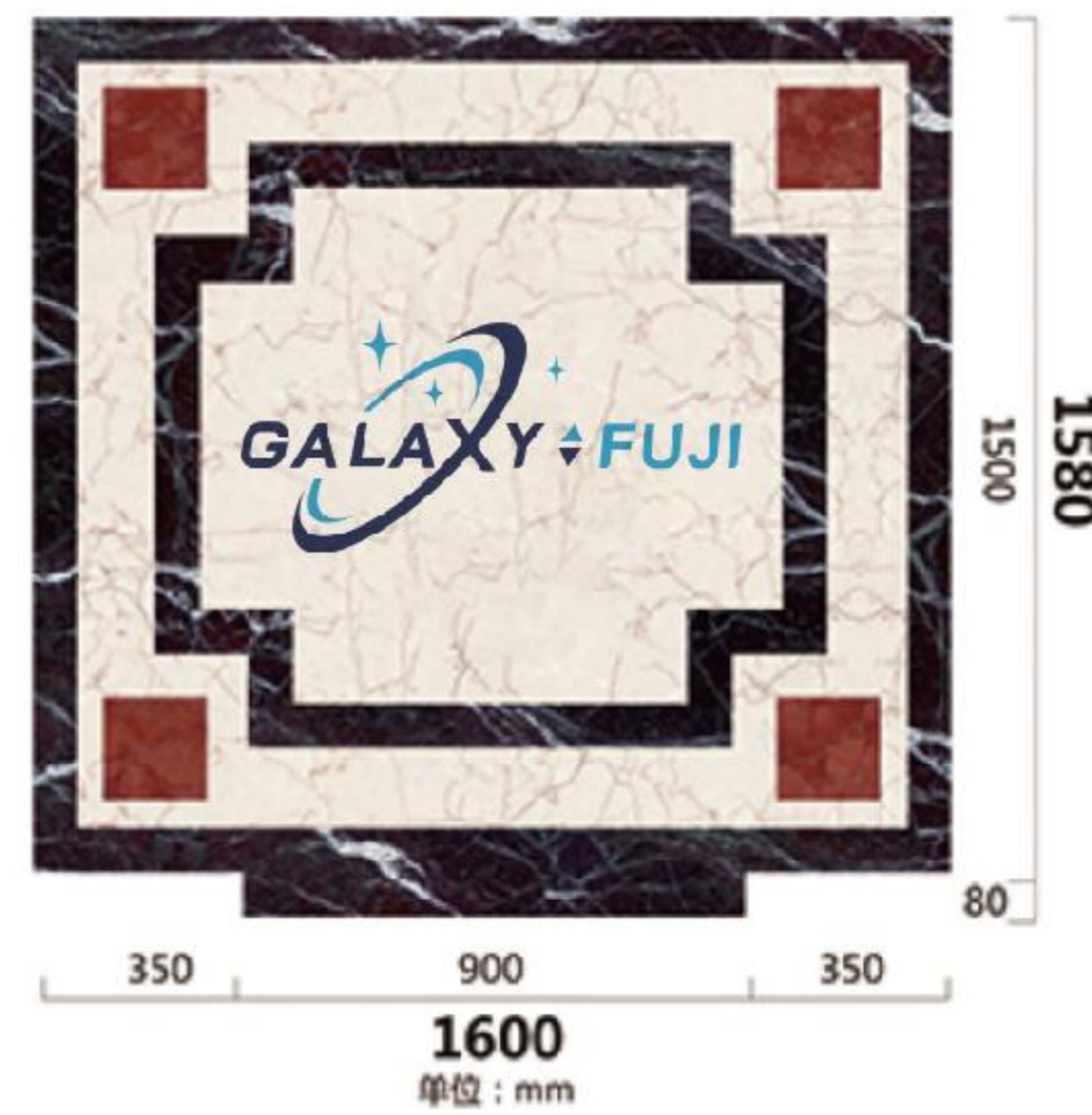
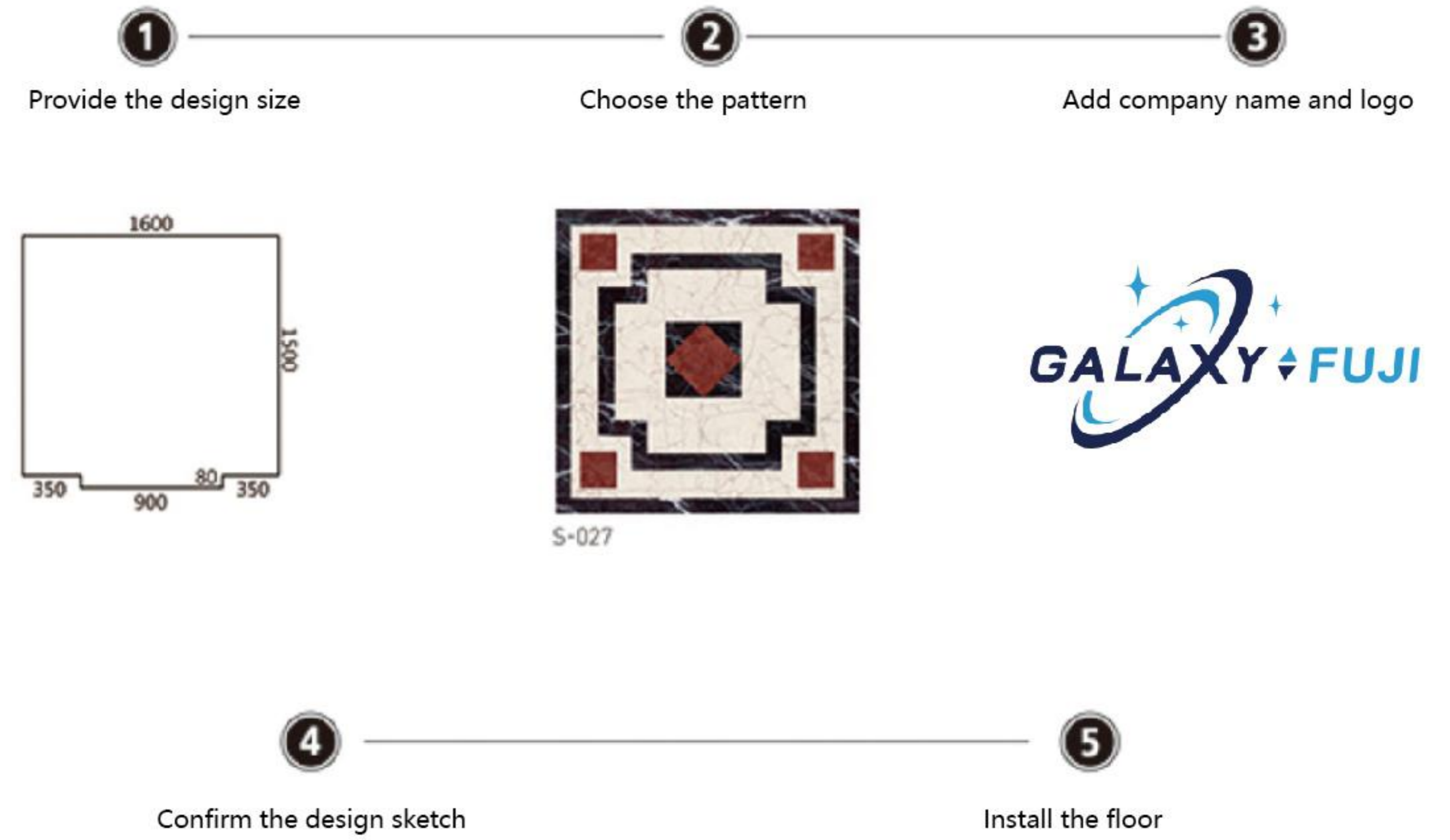



► Floor Series-Customization Series

Common elevator type size measurement methods

Simply draw the size sketch

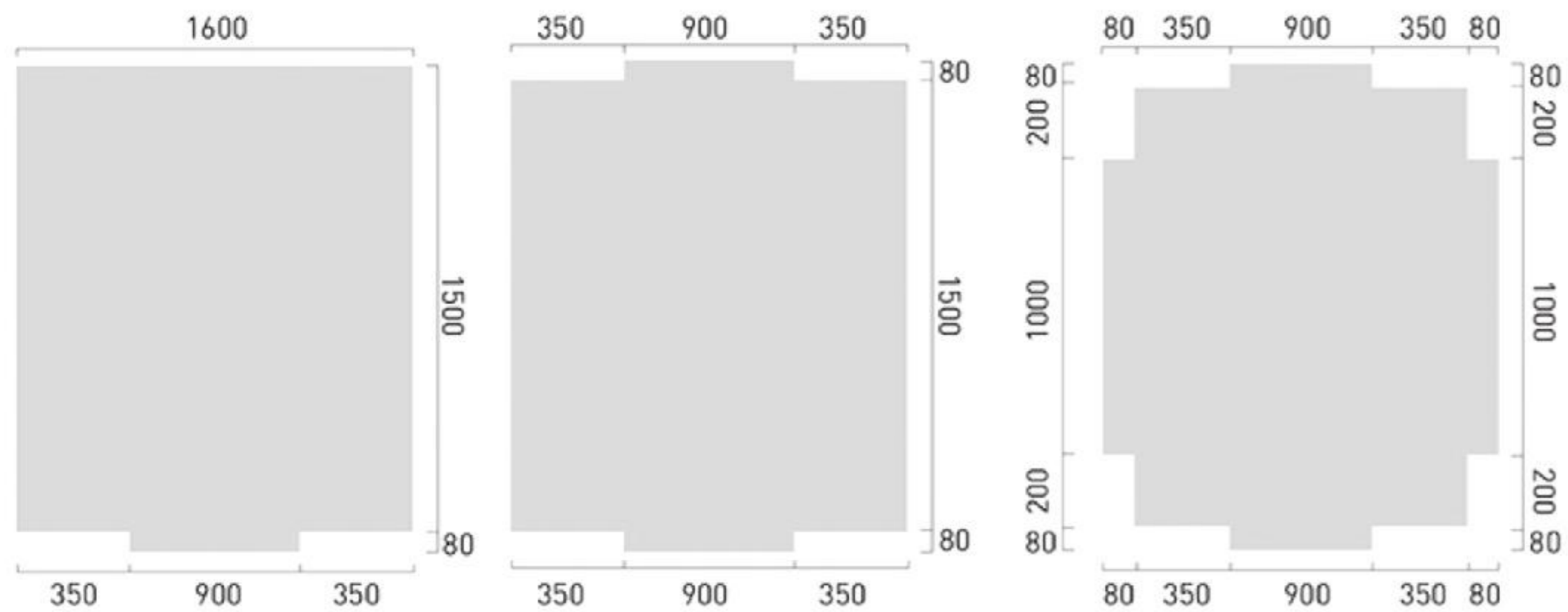

Standard elevator

Through door elevator

Special-shaped elevator

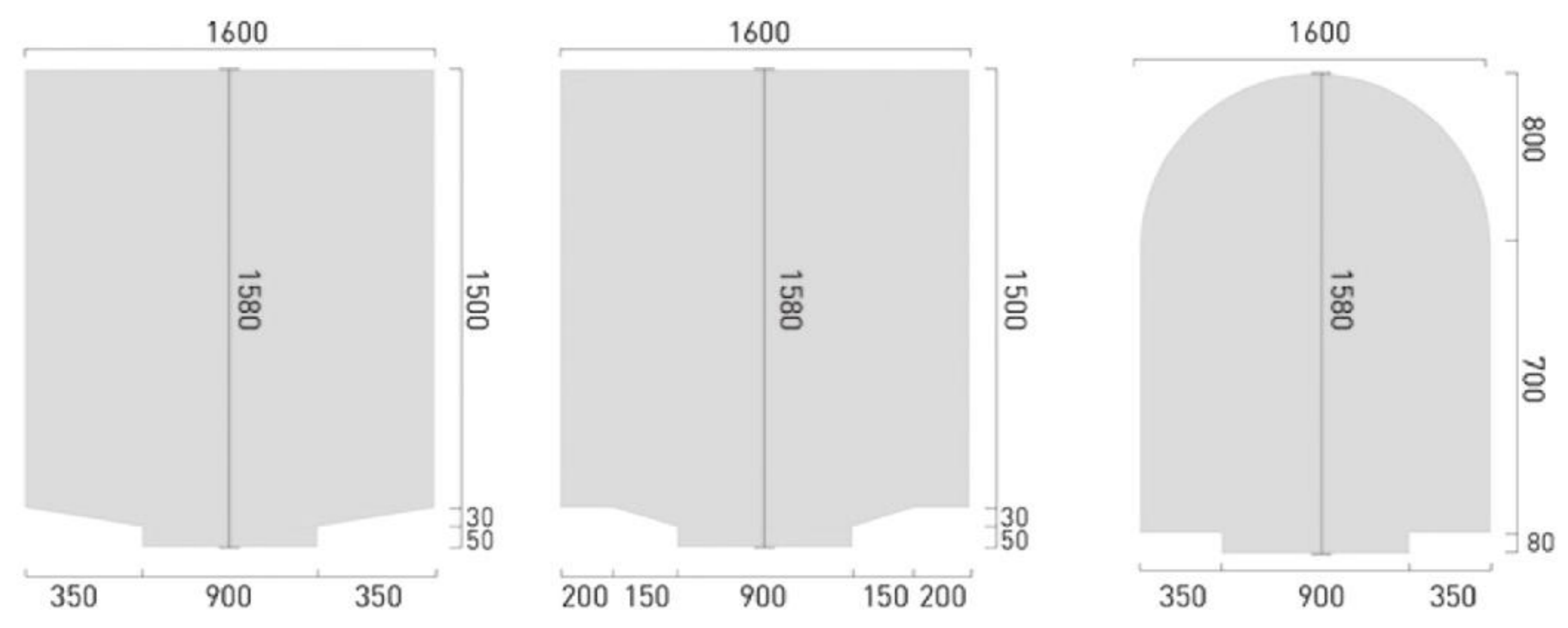

Bevel edge elevator I

Bevel edge elevator II

Panoramic elevator

► Floor Series-Classical Marble Patterns



·GF-S001    ·GF-S002    ·GF-S003    ·GF-S004    ·GF-S005    ·GF-S006    ·GF-S007

► Floor Series-Chinese Brush Drawing Series



·GF-ZS002

·GF-ZS003

·GF-ZS004

·GF-ZS005

·GF-ZS009

·GF-ZS010

► Floor Series-Simulated Carpet Pattern Series



·GF-L001

·GF-L002

·GF-L003

·GF-L004

·GF-L005

·GF-L006

► Floor Series-Wood Grain Series



·GF-M001

·GF-M002

·GF-M003

·GF-M004

·GF-M006

·GF-M007

► Floor Series-Advertising Art Series



·GF-G001

·GF-G002

·GF-G003

·GF-G004

·GF-G005

·GF-G006



► Ceiling Lights Series

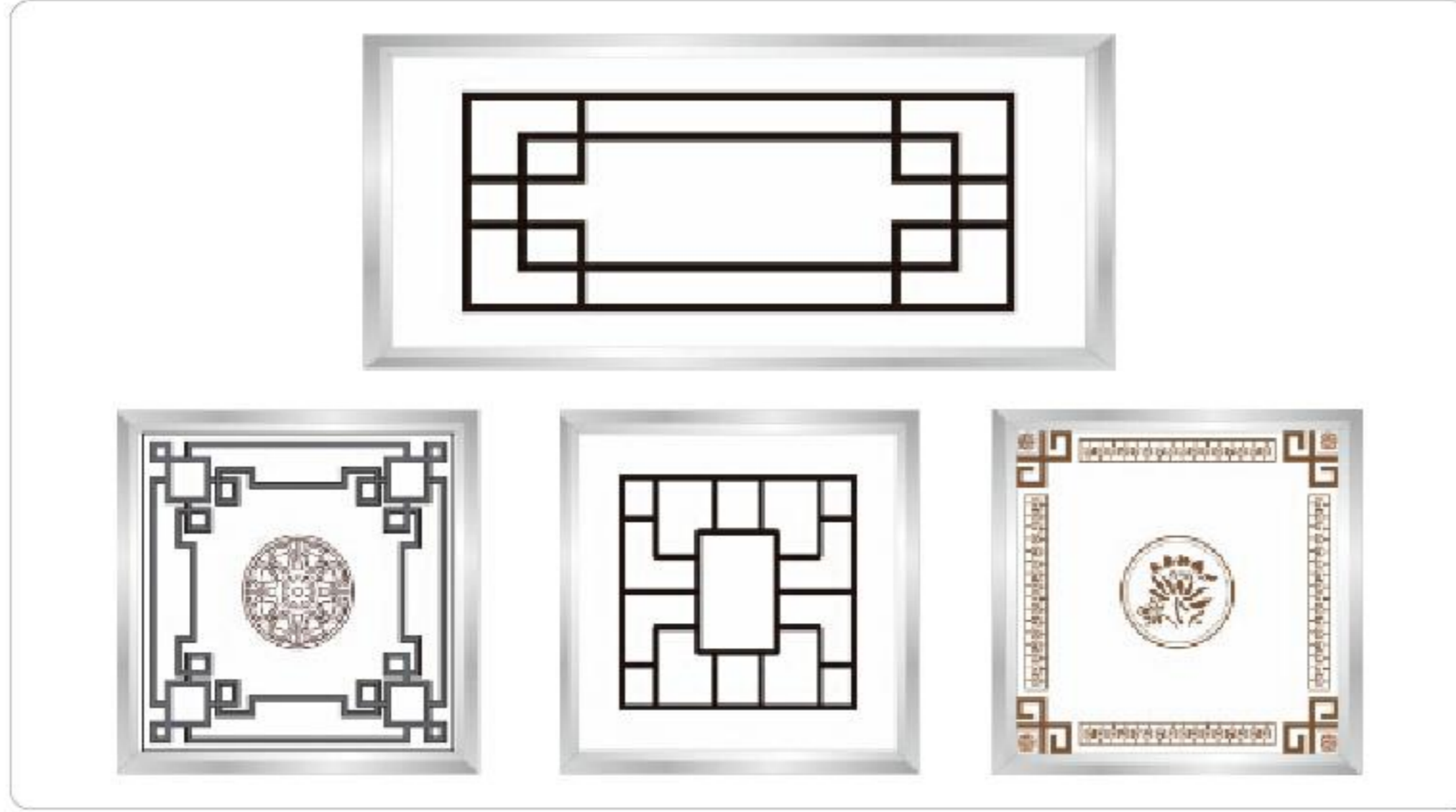

► Landing Door Series



► Semi-Automatic Elevator Door System

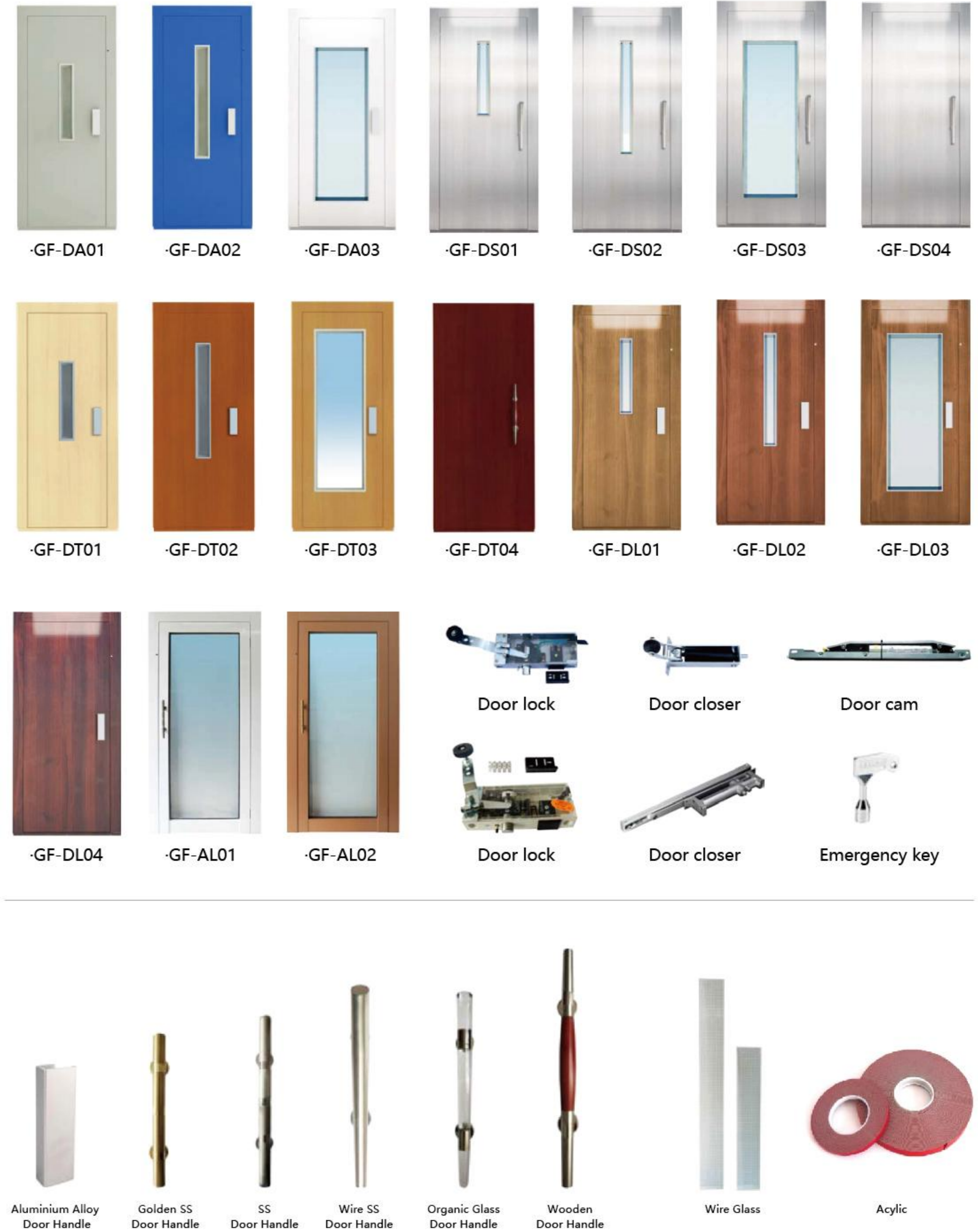



## ▶ Hand Gesture Calling Landing System

**Product Parameters**

- 1, Sensing Method: infrared motion sensing of human hand.
- 2, Sensing Objects: human hands, gloves
- 3, Gesture Effective Range: distance from 5 to 15cm; angle:  $\pm 30$  degree horizontally forward of the center of the device
- 4, Power Voltage: input rated DC12-24V
- 5, Device Consumption: Maximum 1 W
- 6, Relay Pull-in time: 2 seconds
- 7, Available Time Interval between up calling and down calling: 1 second
- 8, Working Environment Temperature:  $-20^{\circ}\text{C} \sim 60^{\circ}\text{C}$
- 9, Storage Temperature:  $-20^{\circ}\text{C} \sim 70^{\circ}\text{C}$

# Anti-epidemic Products



► Intelligent Elevator Ultraviolet Disinfection System

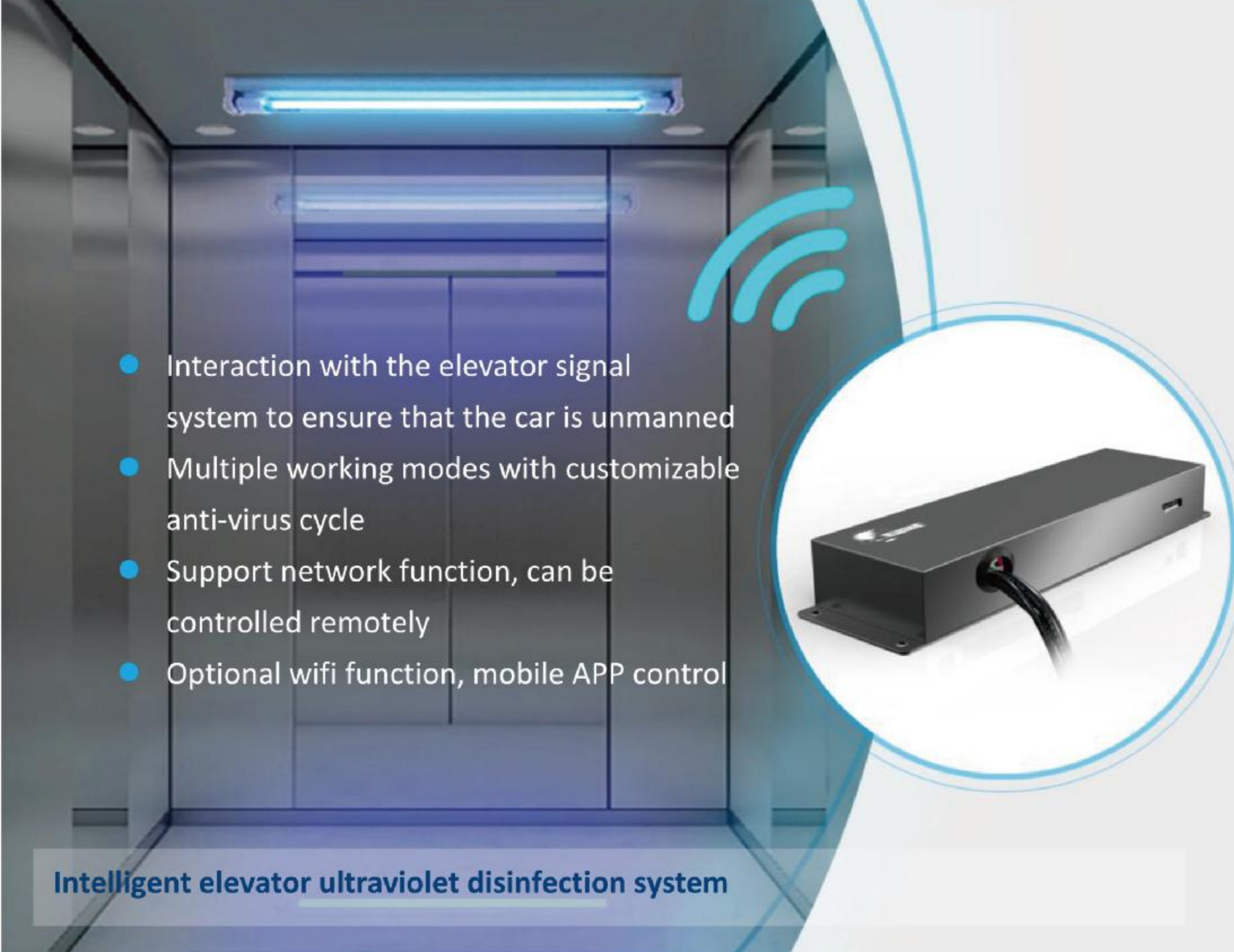

- Interaction with the elevator signal system to ensure that the car is unmanned
- Multiple working modes with customizable anti-virus cycle
- Support network function, can be controlled remotely
- Optional wifi function, mobile APP control

**Intelligent elevator ultraviolet disinfection system**

► Anion Sterilization Cross Flow Fan

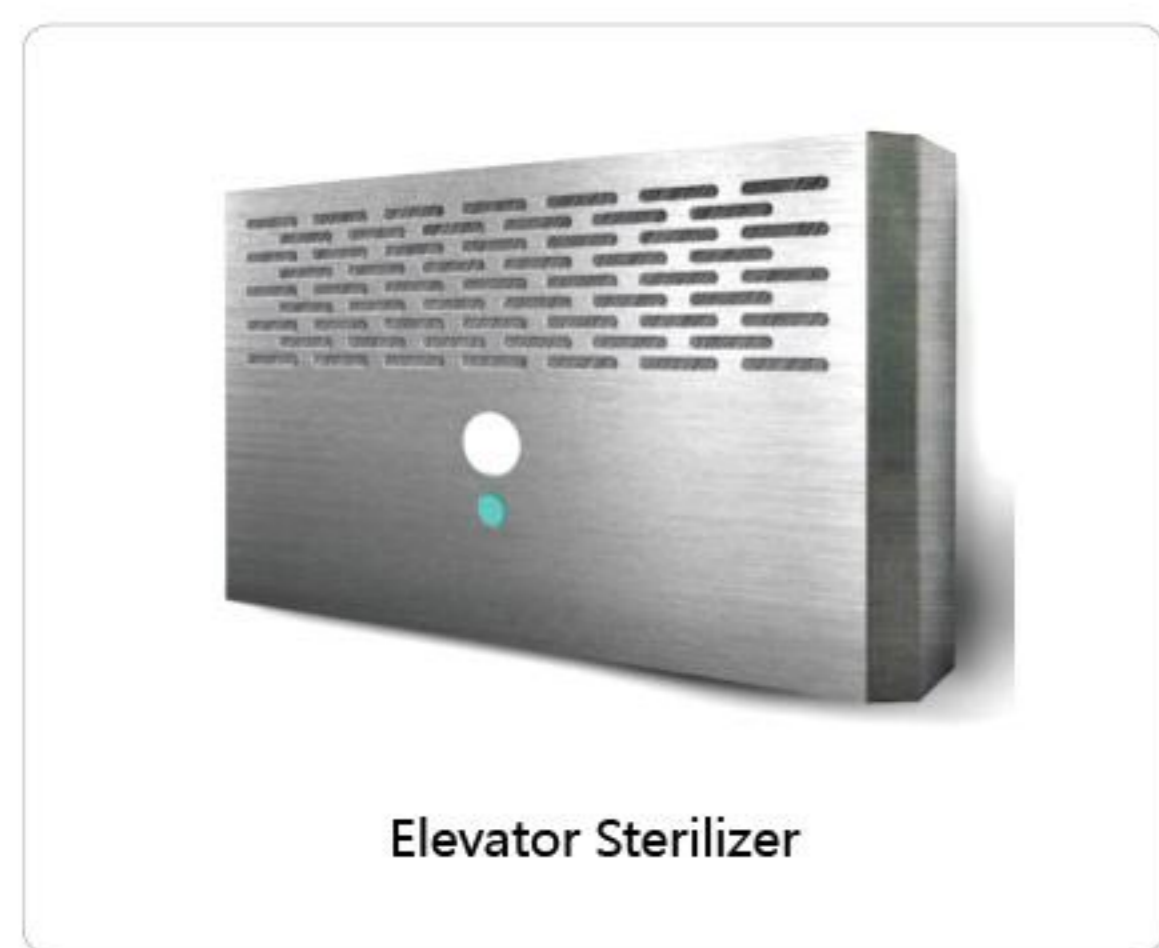



# Escalator Parts

- Step Series
- Handrail Series
- Pallet Series
- Frame Series
- Comb Plate Series
- Pulley Group Series
- Cover Plate Series
- Handrail Pressure Chain Series
- Rubber Entry & Exit Series
- Riding Wheel Series
- Roller Series
- Rotary Chain Series
- Elevator Door Wheel Series
- Glass Holder Series
- Escalator Drive
- Contactor Series
- Door Hanging Board Series
- Escalator Skirt Brush
- Screws Pack Series
- Rope Series
- Metal Machining Parts Series
- Escalator Fitting Series
- Parts Series
- Escalator Running Direction Indicator Series
- PCB Series



## ▶ Step Series

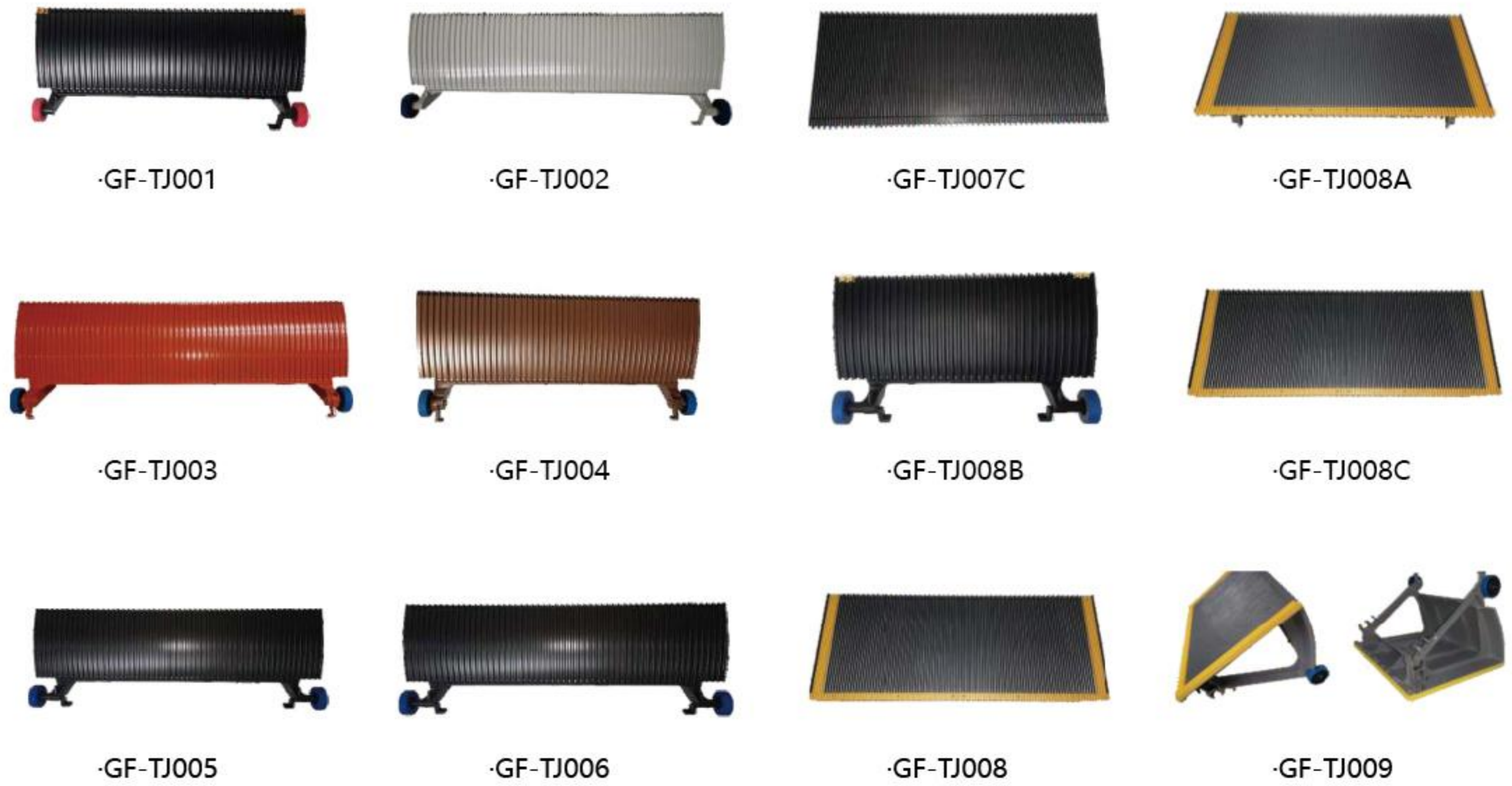

## ▶ Handrail Series





► Pallet Series



► Frame Series

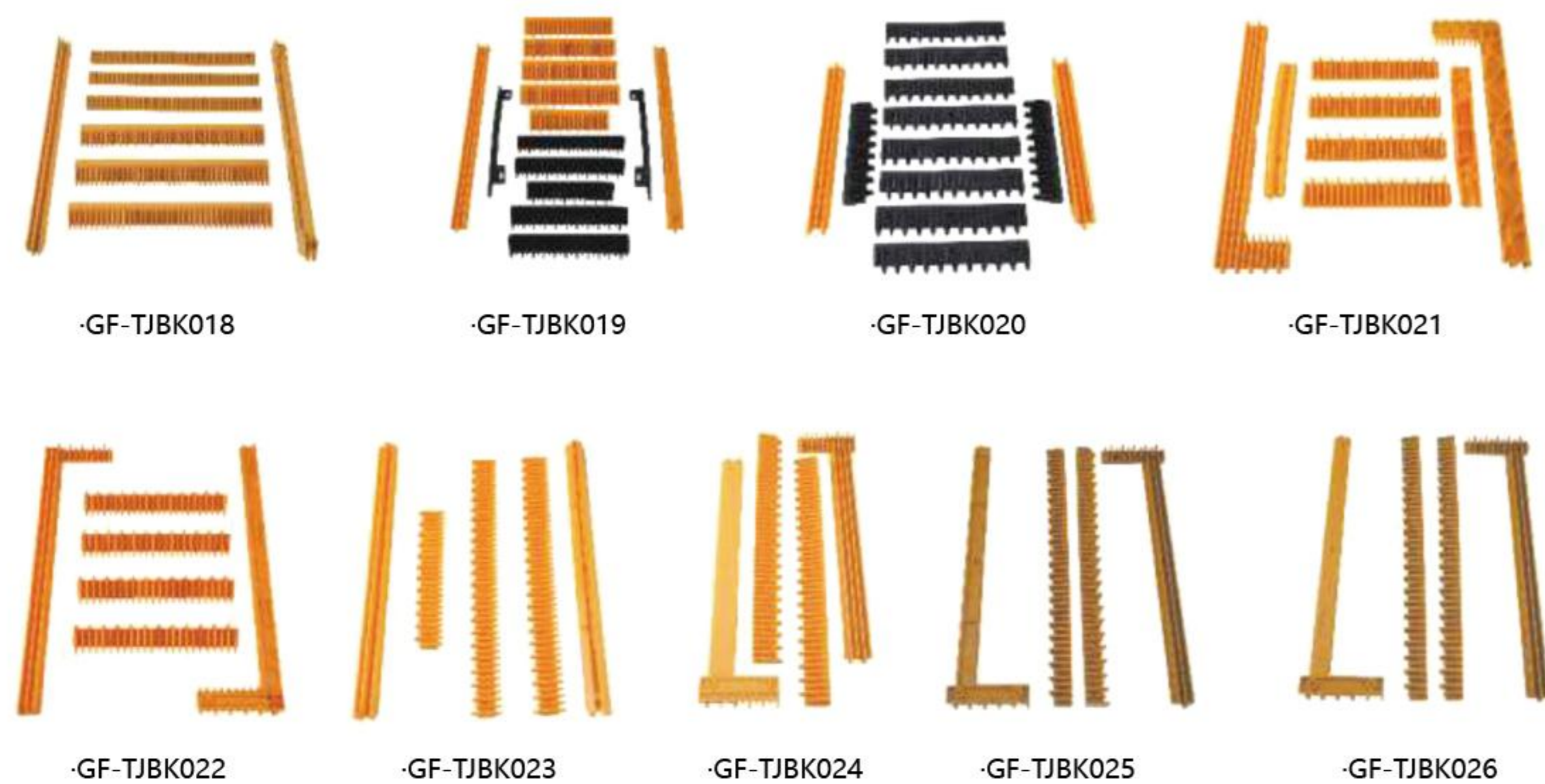

► Comb Plate Series



► Pulley Group Series





► Cover Plate Series

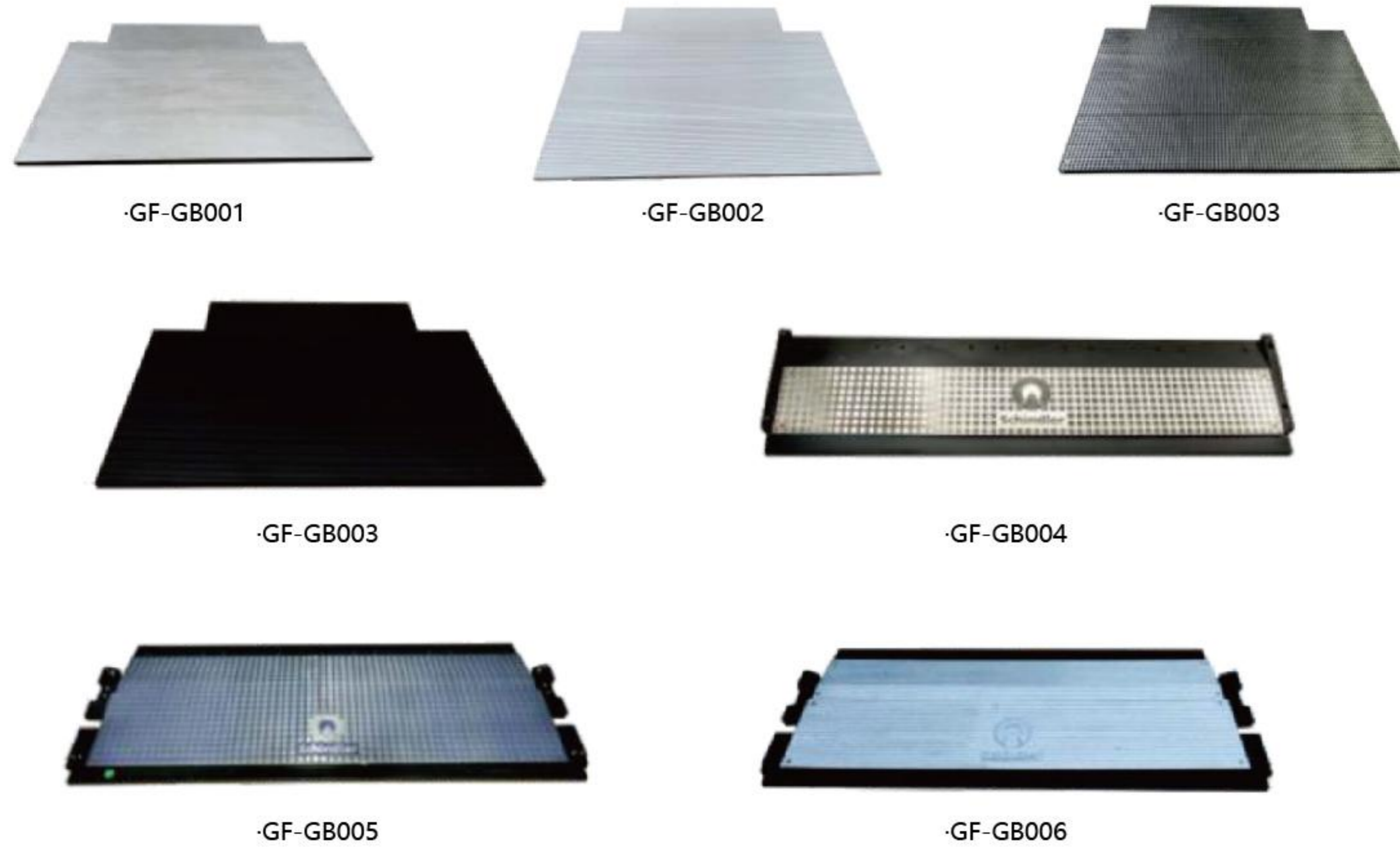

► Rubber Entry & Exit Series



► Handrail Pressure Chain Series



► Riding Wheel Series





▶ Roller Series



▶ Rotary Chain Series



▶ Elevator Door Wheel Series



▶ Glass Holder Series

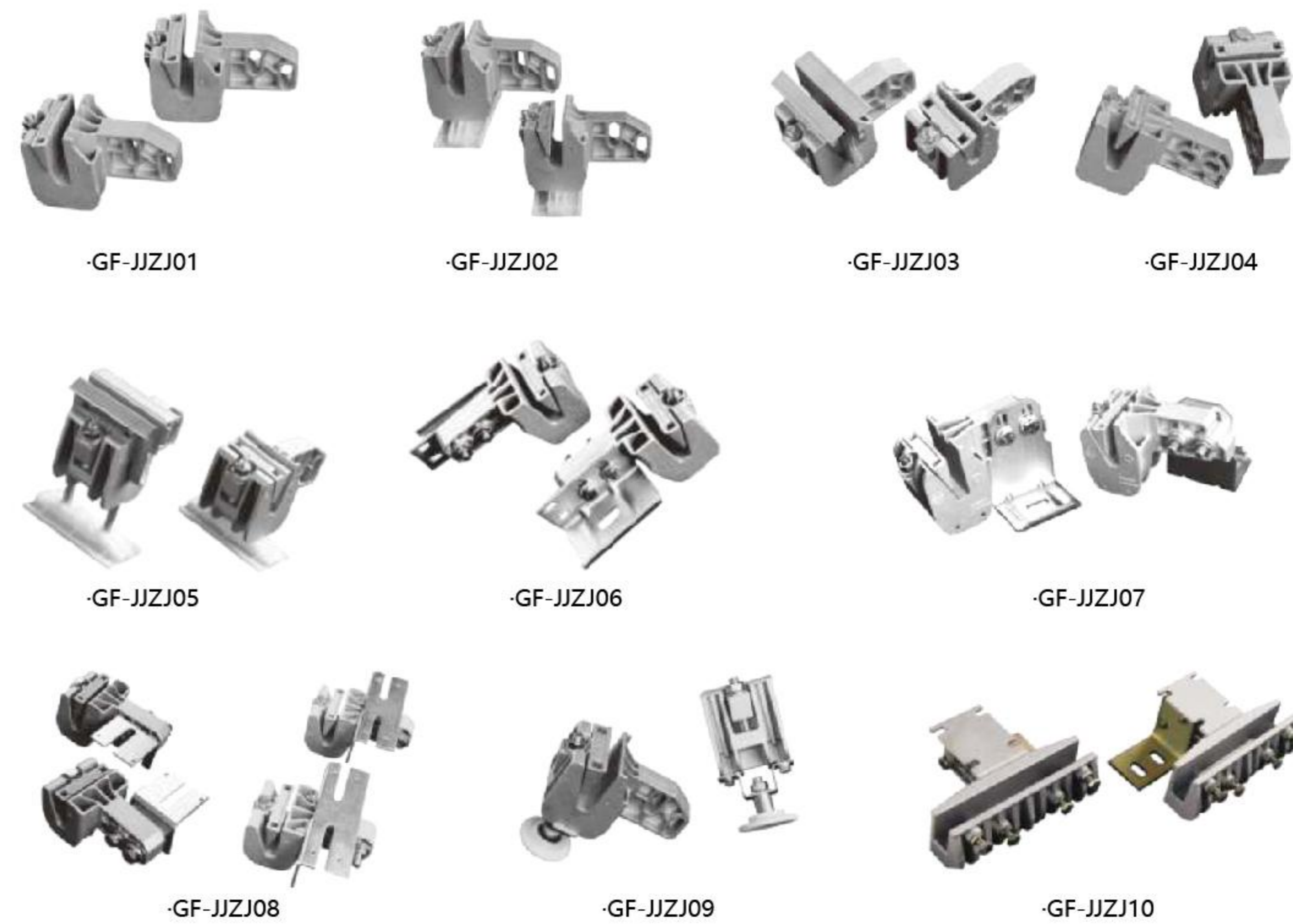



► Escalator Drive

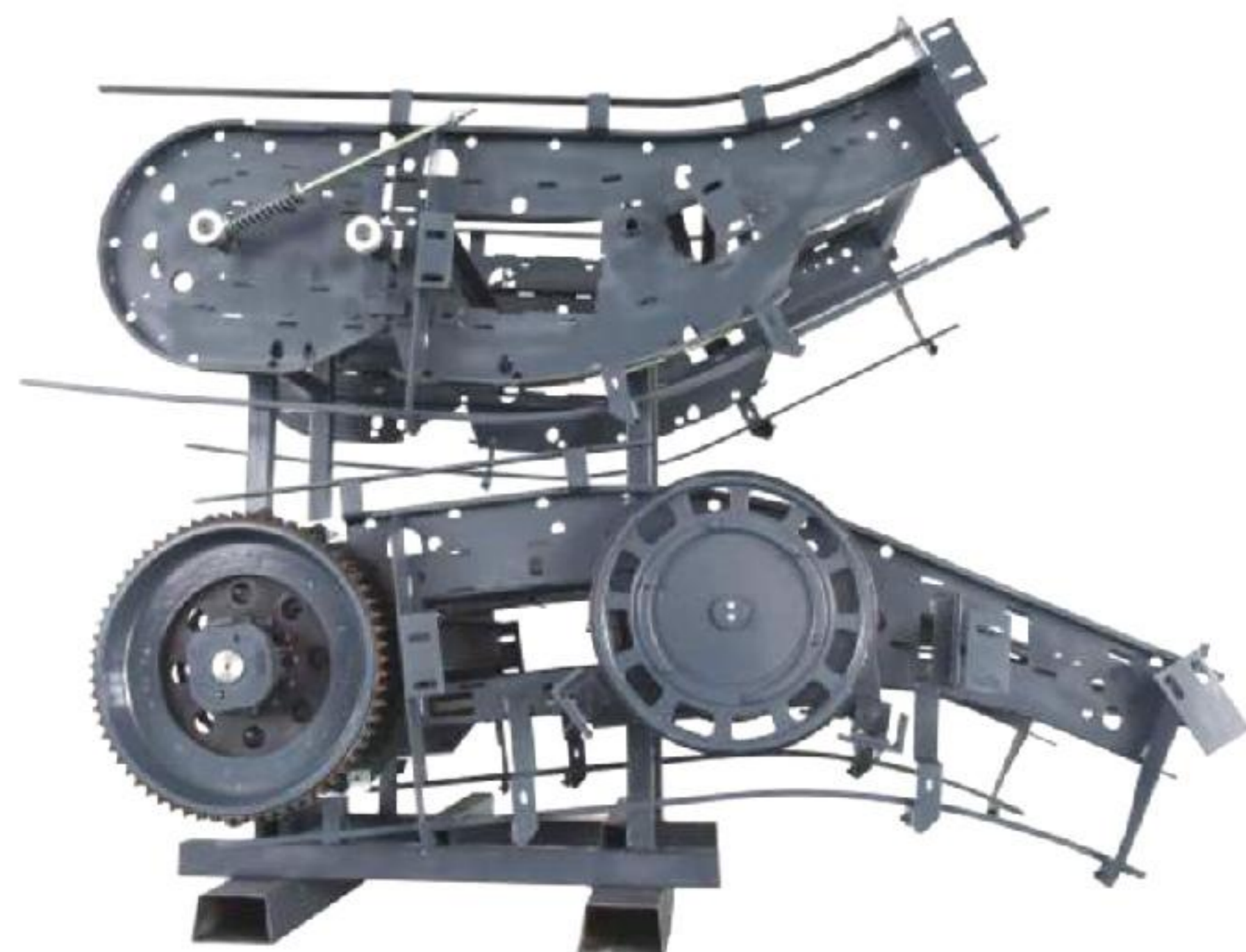

► Transformer



TDB-1100-22 21 18



KMZ-1000-02



AC1000VC220AN2



AC1000VC220AN2



XAA225AS2

► Contactor Series



GF-C0319



GF-C0320



GF-C0321



GF-C0322



GF-C0335



GF-C0334



GF-C0333



GF-C0131



GF-C0332



GF-C0331



GF-C0330



GF-C0103

► Door Hanging Board Series



For Guangri



For Guangri



For Hitachi



For Hitachi



For Mitsubishi



For XINDA



For Mitsubishi



For OTIS



For OTIS

► Escalator Skirt Brush

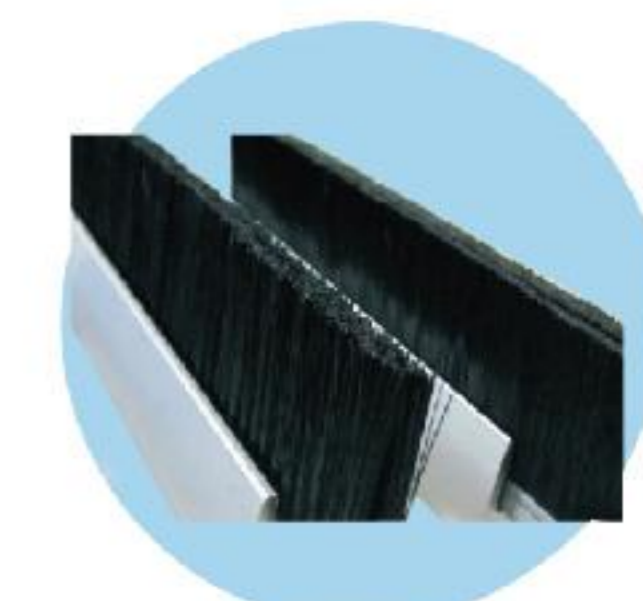
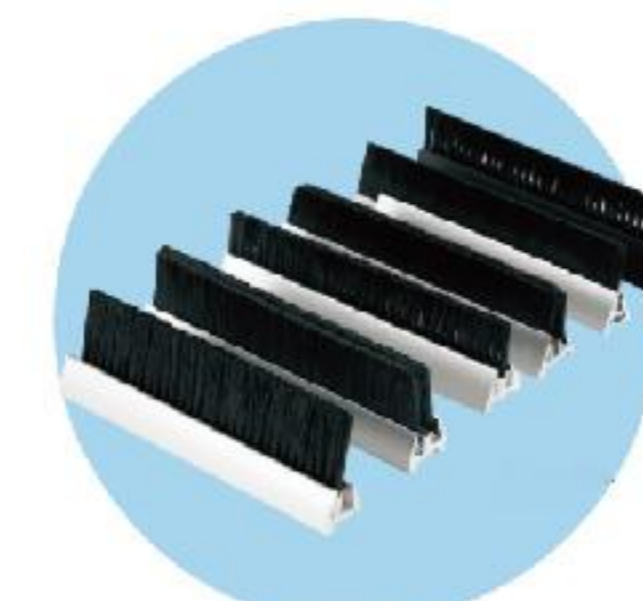



► Screws Pack Series

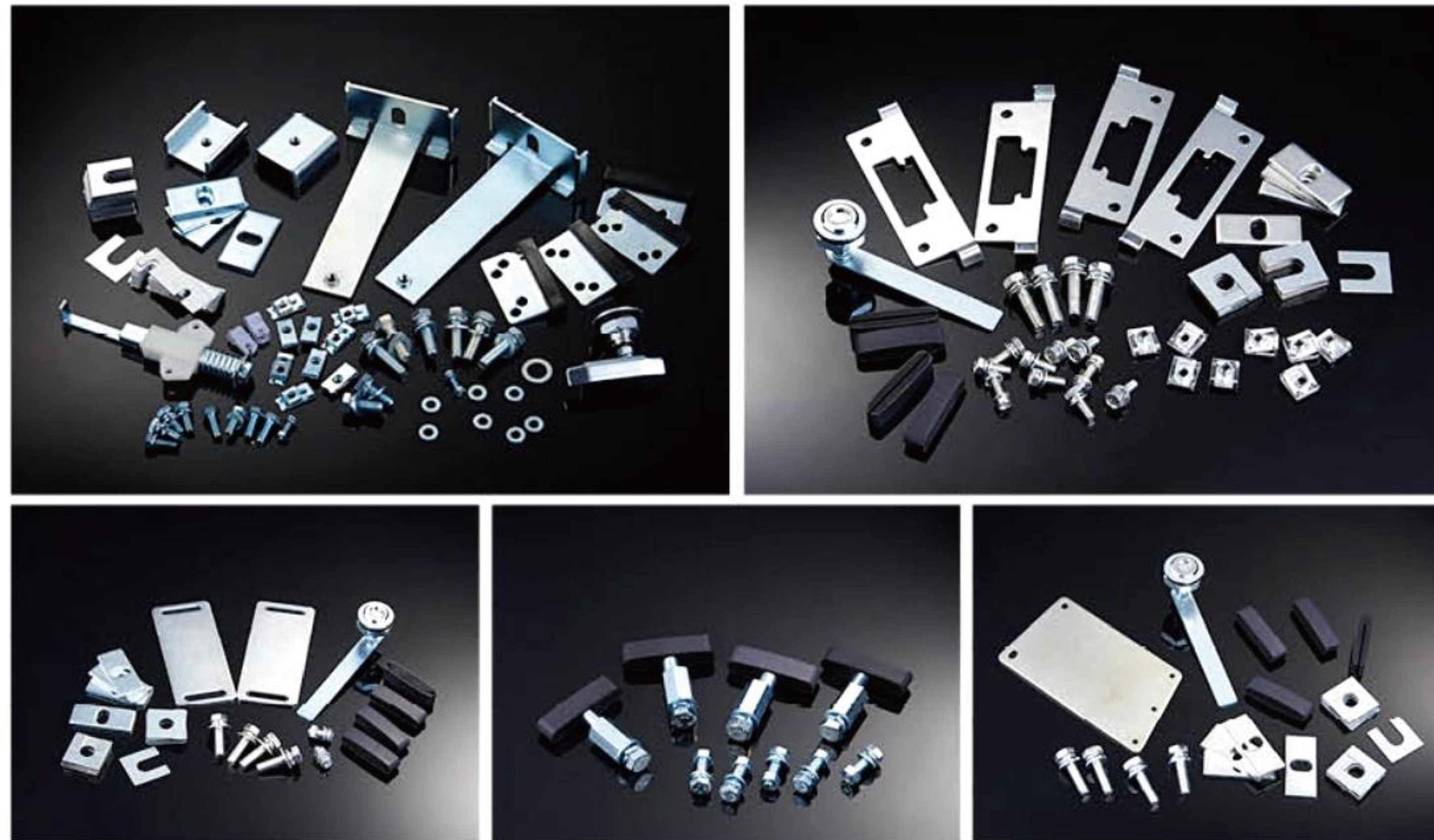

► Rope Series



Type:	Spring hammer wire rope Wire rope
Standard:	The weight of steel wire rope Air wire rope
Diameter:	ø3,ø3.18
Specification:	OP=700-1200
Pull force reirements:	Transmission rope, riveting tension > 2000N The hammer riveting pull rope, > 3000N
Steel wire rope head screw:	The commonly used M6,M8,M10

► Metal Machining Parts Series



► Escalator Fitting Series





► Parts Series



·GF-P254    ·GF-P255    ·GF-P256    ·GF-P257    ·GF-P258  
 ·GF-P259    ·GF-P260    ·GF-P261    ·GF-P262    ·GF-P263  
 ·GF-P264    ·GF-P265    ·GF-P266    ·GF-P267    ·GF-P268  
 ·GF-P269    ·GF-P270    ·GF-P271    ·GF-P272    ·GF-P273

► Escalator Running Direction Indicator Series



► PCB Series

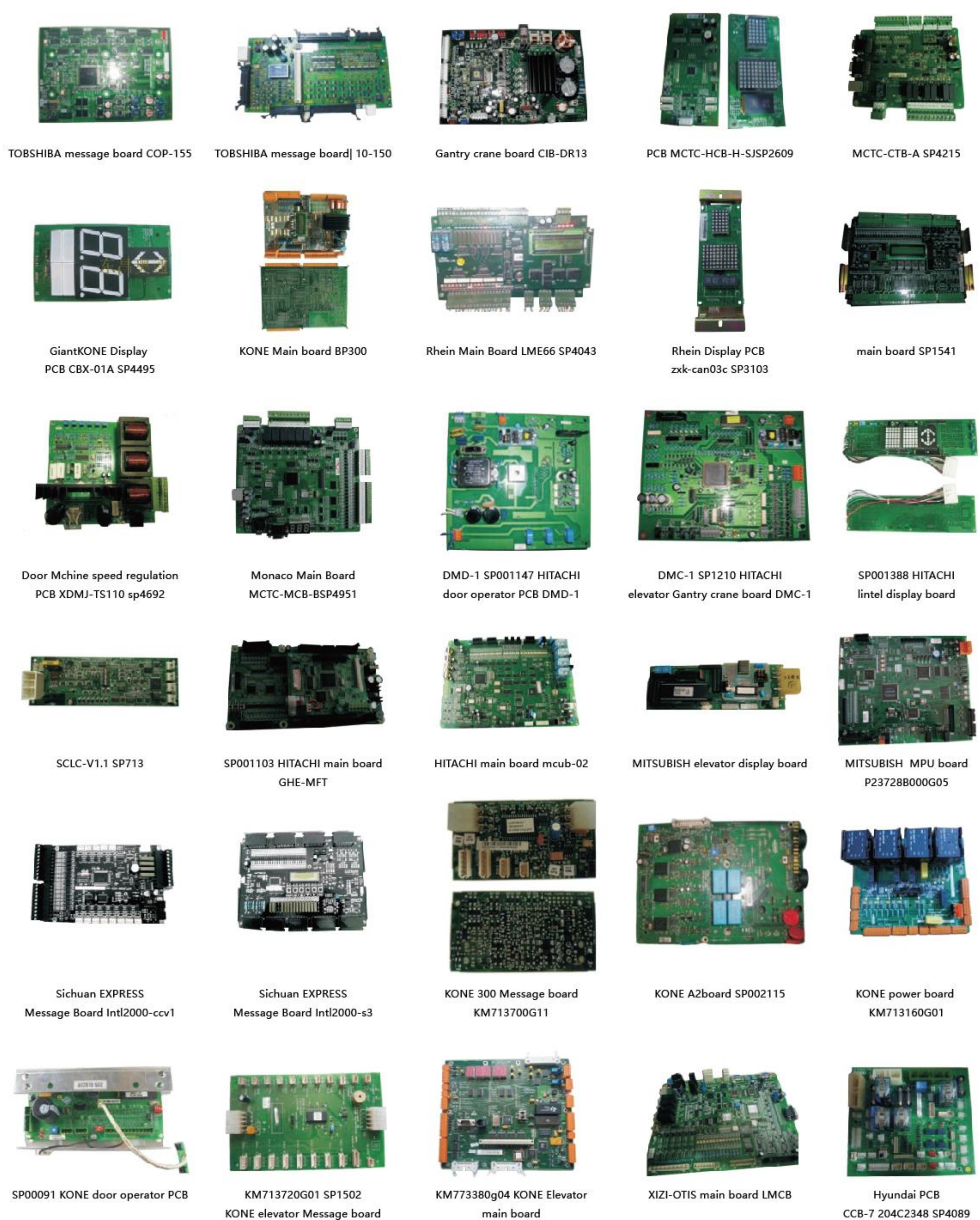

TOBISHIBA message board COP-155    TOBISHIBA message board| 10-150    Gantry crane board CIB-DR13    PCB MCTC-HCB-H-SJSP2609    MCTC-CTB-A SP4215  
 GiantKONE Display PCB CBX-01A SP4495    KONE Main board BP300    Rhein Main Board LME66 SP4043    Rhein Display PCB zxc-can03c SP3103    main board SP1541  
 Door Mchine speed regulation PCB XDMJ-TS110 sp4692    Monaco Main Board MCTC-MCB-BSP4951    DMD-1 SP001147 HITACHI door operator PCB DMD-1    DMC-1 SP1210 HITACHI elevator Gantry crane board DMC-1    SP001388 HITACHI intel display board  
 SCLC-V1.1 SP713    SP001103 HITACHI main board GHE-MFT    HITACHI main board mcub-02    MITSUBISHI elevator display board    MITSUBISHI MPU board P23728B000G05  
 Sichuan EXPRESS Message Board Intl2000-ccv1    Sichuan EXPRESS Message Board Intl2000-s3    KONE 300 Message board KM713700G11    KONE A2board SP002115    KONE power board KM713160G01  
 SP00091 KONE door operator PCB    KM713720G01 SP1502 KONE elevator Message board    KM773380g04 KONE Elevator main board    XIZI-OTIS main board LMCB    Hyundai PCB CCB-7 204C2348 SP4089



► Friction Wheel Series



·GF-MCL009  
Φ690\*220\*35



·GF-MCL003  
Φ587\*30\*-Φ10  
Φ587\*30-Φ12



·GF-MCL005  
Φ587\*30\*-Φ10  
Φ587\*30-Φ12



·GF-MCL004  
Φ456\*30\*-Φ50



·GF-MCL010  
Φ496\*30



·GF-MCL011  
Φ587\*Φ503\*30



·GF-MCL012  
Φ557\*Φ503\*30



·GF-MCL013  
Φ440\*30



·GF-MCL014  
Φ597\*30



·GF-MCL015  
Φ650\*30



·GF-MCL016  
Φ650\*30



·GF-MCL017  
Φ456\*Φ218\*31

► Staircase Cleaning Device



·GF-QSZZ004



·GF-QSZZ001



·GF-QSZZ002

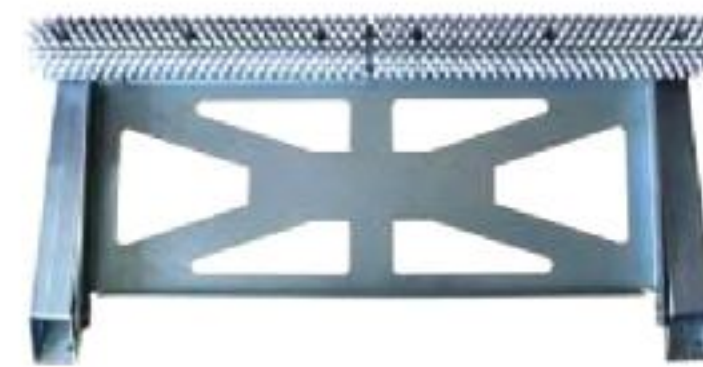

·GF-QSZZ003

